

For the installer

Flue installation instructions



Air flue duct for use with

turboMAX plus .../2 E

turboMAX pro .../2 E

thermoCOMPACT .../2 E

aquaPLUS

PART 1:







Standard Concentric Systems





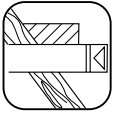
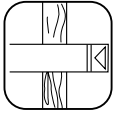
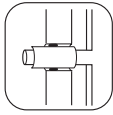
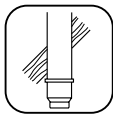

Ø 60/100

PART 2:

Optional Concentric Systems

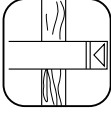
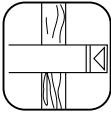
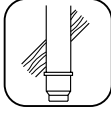
Ø 80/125

		Page
	Requirements	4
	Planning the air/flue duct layout	5
	Alternative termination accessories available	9
	Maximum flue lengths Ø 60/100	10
	Flue restrictor rings	10
	Installation of the horizontal air/flue duct (top outlet)	11
	Preparation	11
	Top outlet flue exiting to rear	11
	Top outlet flue exiting to side	11
	Installation of the horizontal air/flue duct (rear outlet)	14
	Preparation	14
	Preparation of boiler for rear outlet air/flue duct	16
	Installation of the Se-Duct flue	19
	Preparation	19
	Top outlet flue exiting to rear	19
	Top outlet flue exiting to side	19
	Installation of the vertical roof duct	22
	Preparation	22
	Pitched roof	23
	Flat roof	23
	Pitched and flat roof installation	23
	Fitting air/flue duct extensions	25
	Fitting air/flue duct extensions between two 90° elbows	26
	Fitting air/flue duct extensions between two 45° elbows	27
	Installing the air/flue duct sliding sleeve	28

	Page
 Planning the air/flue duct layout	Termination accessories available 29 Maximum flue lengths Ø 80/125 32 Flue restrictor rings 33
 Fitting the appliance flue outlet adapter to the boiler	35
 Installation of the horizontal air/flue with extensions	Preparation 37 Side flue installations 37
 Installation of the horizontal air/flue duct and terminal accessory (80/125)	Preparation 39 Fitting extensions 40 Connect the flue assembly to the adaptor 40
 Installation of the vertical roof duct	Preparation 41 Pitched roof 42 Flat roof 42 Pitched and flat roof installation 42 Connect the flue assembly to the adaptor 44
 Fitting air/flue duct extensions	45
 Fitting air/flue duct extensions between two 90° elbows	46
 Fitting air/flue duct extensions between two 45° elbows	47
 Installing the air/flue duct sliding sleeve	48



REQUIREMENTS

- ☞ Vaillant turboMAX, thermoCOMPACT and aquaPLUS boilers are certified as heating boilers with corresponding flue systems according to EC Directive 90/396/EEC on gas-fired devices. This installation manual is covered by this certification and is referred to in the design approval test certificate.
- ☞ These instructions should be read in conjunction with the instructions for installation and servicing supplied with the boiler.
- ☞ Ensure also that all legislation, rules, regulations and directives mentioned in the installation instructions are observed.
- ☞ The installation of the boiler and its flue must be carried out by a competent person who is registered with CORGI (The Council for Registered Gas Installers).
- ☞ The installation of the boiler and flue must be in accordance with the Gas Safety (Installation and Use) Regulations 1998 and the Building Regulations and BS 5440 Part 1.
- ☞ The requirements for flue termination detailed in the boiler installation instructions must be observed.
- ☞ Two types of flue system are available for turboMAX, thermoCOMPACT and aquaPLUS boilers. The standard concentric flue system (100 mm outside diameter) and a larger diameter concentric system (125 mm outside diameter) which allows longer air/flue duct lengths to be achieved.
- ☞ The air/flue duct operates at very low temperatures therefore no clearance is necessary between the air duct and adjacent services.
- ☞ Ensure while installation work is being carried out that no debris such as swarf, filings or fragments of mortar are allowed to remain in the air/flue duct.



Alternative termination accessories available



303 807 = Horizontal air/flue duct with 90° elbow and terminal (750 mm)



303 806 = Telescopic horizontal air/flue duct with 90° elbow and terminal (450 - 650 mm; turboMAX and thermoCOMPACT only)



303 817 = Rear outlet flue and terminal (for wall thicknesses 200 mm to 305 mm; turboMAX and thermoCOMPACT only)



303 810 = Se-duct flue accessory



303 800 = Vertical air/flue duct and terminal accessory

Optional connection accessories	Accy. No.	303 807	303 806	303 810	303 800
Air/flue duct extension 500 mm - Ø 60/100	303 801	x	x	x	x
Air/flue duct extension 1000 mm - Ø 60/100	303 802	x	x	x	x
Air/flue duct extension 1960 mm - Ø 60/100	303 803	x	x	x	x
Telescopic air/flue duct extension 500 - 800 mm - Ø 60/100	303 804	x	x	x	x
2 x 45° Bends Ø 60/100	303 809	x	x	x	x
90° Elbow Ø 60/100	303 808	x	x	x	x
Air/flue duct 15° offset Ø 60/100	303 820	x	x	x	x
Air/flue duct (adjustable) offset (33 -56 mm) Ø 60/100	303 819	x	x	x	x
Flue support clips (Pack of 5), Ø 100	303 821	x	x	x	x
Sliding sleeve Ø 60/100	303 816	x	x	x	x
Adjustable roof tile	9076				x
Flat roof collar-piece	9056				x



PLANNING THE AIR/FLUE DUCT LAYOUT

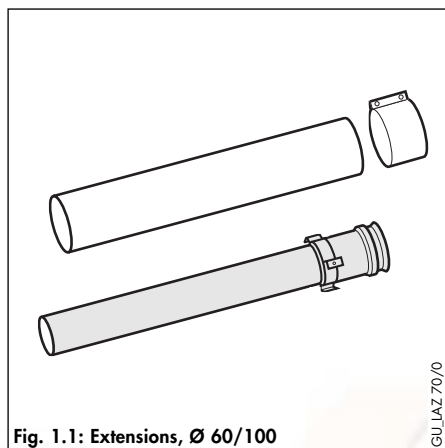

Fig. 1.1: Extensions, Ø 60/100

GU_LAZ 70/0

Air/flue duct extension 500 mm, Ø 60/100

Accy. No.: 303 801

Air/flue duct extension 1000 mm, Ø 60/100

Accy. No.: 303 802

Air/flue duct extension 1960 mm, Ø 60/100

Accy. No.: 303 803

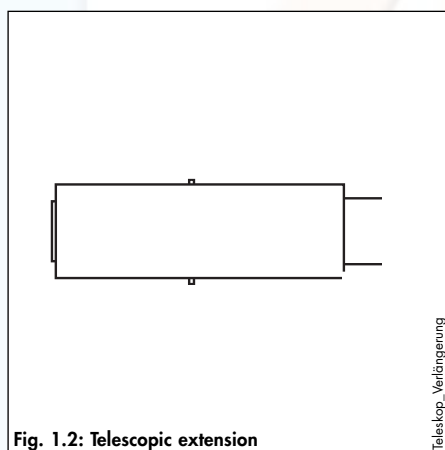

Fig. 1.2: Telescopic extension

Teleskop_Verlängerung

Telescopic air/flue duct extension 500 – 800 mm Ø 60/100

Accy. No.: 303 804

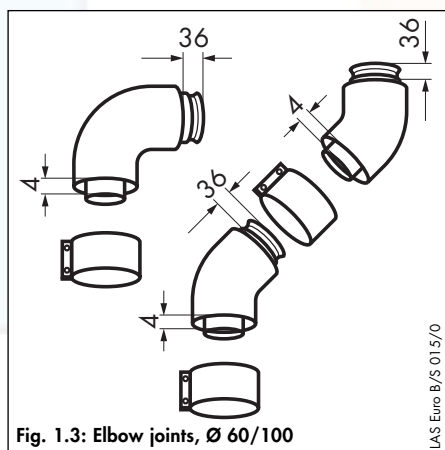

Fig. 1.3: Elbow joints, Ø 60/100

LAS Euro B/S 015/0

90° Elbow, Ø 60/100

Accy. No.: 303 808

2 x 45° Bends, Ø 60/100

Accy. No.: 303 809



Abb. 1.4: Adjustable offset pipe

LAS Euro B/S 070/0GB

Air/flue duct 15° offset Ø 60/100

Accy. No.: 303 820

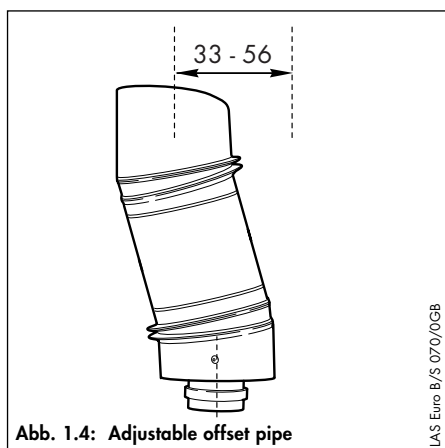
Air/flue duct (adjustable) offset pipe Ø 60/100

Accy. No.: 303 819



Use one clip per extension to support the air/flue duct.

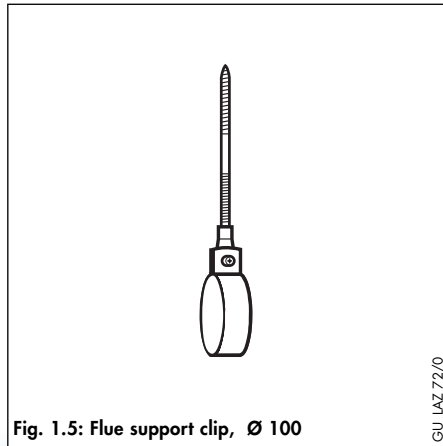

Fig. 1.5: Flue support clip, Ø 100

Flue support clips, Ø 100 (Pack of 5)
Accy. No.: 303 821

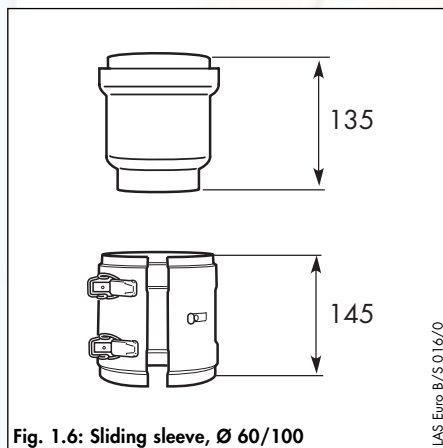

Fig. 1.6: Sliding sleeve, Ø 60/100

Sliding sleeve, Ø 60/100
Accy. No.: 303 816

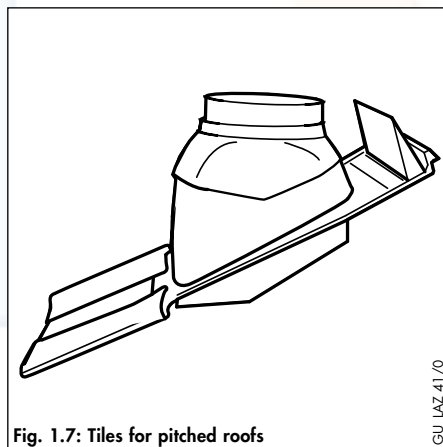

Fig. 1.7: Tiles for pitched roofs

Adjustable roof tile
Accy. No.: 9076

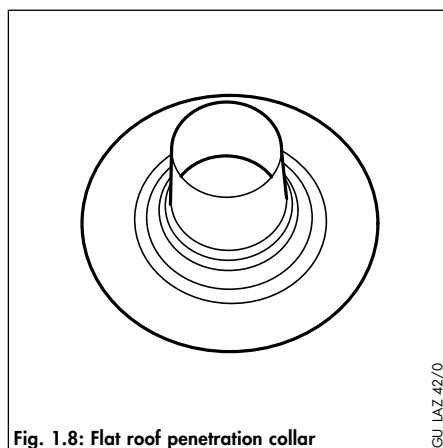

Fig. 1.8: Flat roof penetration collar

Flat roof penetration collar
Accy. No.: 9056



PLANNING THE AIR/FLUE DUCT LAYOUT

Maximum flue lengths Ø 60/100

		thermoCOMPACT 615/2 E	thermoCOMPACT 620/2 E	thermoCOMPACT 624/2 E turboMAX pro 24/2 E turboMAX plus 824/2 E	thermoCOMPACT 628/2 E turboMAX pro 28/2 E turboMAX plus 828/2 E	thermoCOMPACT 637 E turboMAX plus 837 E aquaPLUS
Horizontal flue systems 303 807 303 806 303 810	Max. permitted flue length (L)	5.3	5.3	4.5	3.3	3.0
		Maximum length of flue is reduced by 1.0 m for each additional 90° elbow. Maximum length of flue is reduced by 0.5 m for each additional 45° elbow.				
Vertical flue systems 303 800	Max. permitted flue length (L)	6.3	6.3	5.5	4.3	4.0
		Maximum length of flue is reduced by 1.0 m for each additional 90° elbow. Maximum length of flue is reduced by 0.5 m for each additional 45° elbow.				

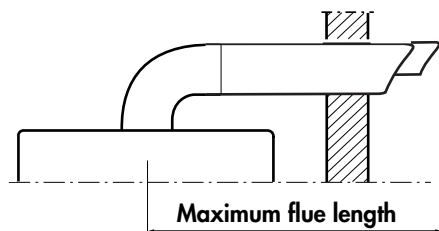

Fig. 1.9

LAS Euro B/S 074/0

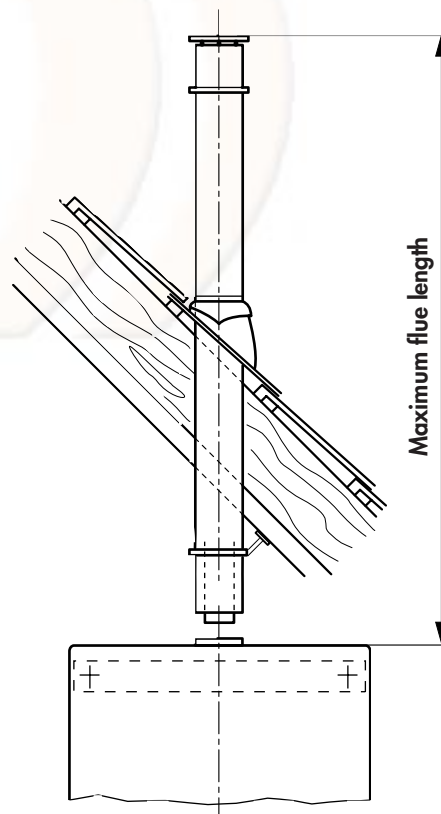

Fig. 1.10

LAS Euro B/S 075/0



	Total equivalent flue length (incl. terminal any bends / elbows used)			
	thermoCOMPACT 615/2 E	thermoCOMPACT 620/2 E	thermoCOMPACT 624/2 E turboMAX plus 824/2 E turboMAX pro 24/2 E	thermoCOMPACT 628/2 E turboMAX plus 828/2 E turboMAX pro 28/2 E
Use restrictor A	—	< 6.3 m	—	—
Use restrictor C	—	—	< 5.5 m	—
Use restrictor D	—	—	—	< 2.3 m
No flue restrictor	—	—	—	> 2.3 m

Flue restrictor rings

The flue restrictor ring marked A, C or D is packed with the boiler connection accessories. The restrictor ring should be fitted as shown in the diagram according to the equivalent flue length in the table.

The total equivalent flue length is the total length of the flue (including the terminal assembly for vertical flues), plus the resistance of any bends or elbows used.

- equivalent length of 90° elbow is 1 m
- equivalent length of 45° elbow is 0.5 m

- Push the restrictor (1) into the flue connection of the appliance (3)
- Connect the flue/elbow (2) into the flue connection of the appliance (3).

Note:

thermoCOMPACT 615 boilers do not require a separate restrictor ring and are supplied without the restrictor. The required restriction is designed into the flue connection piece for these boilers.

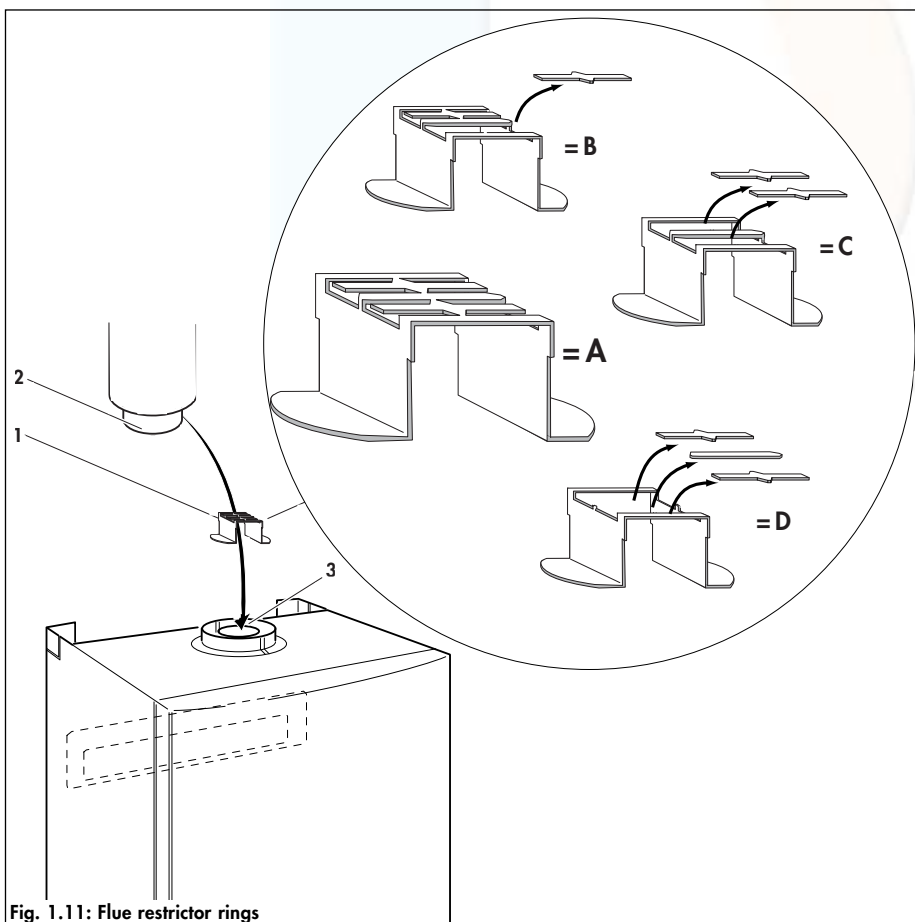

Fig. 1.11: Flue restrictor rings



PLANNING THE AIR/FLUE DUCT LAYOUT

		Total equivalent flue length (incl. terminal any bends / elbows used)		
		aquaPLUS	thermoCOMPACT 637 E	turboMAX plus 837 E
Use restrictor F0	—	< 2.5 m	< 2.5 m	< 2.5 m
Use restrictor F1	—	2.5 - 3.3 m	2.5 - 3.3 m	2.5 - 3.3 m
Use restrictor F2	—	—	—	—
No flue restrictor	—	> 3.3 m	> 3.3 m	> 3.3 m

Flue restrictor rings

The flue restrictor ring marked F0 and F1 is packed with the boiler connection accessories. The restrictor ring should be fitted as shown in the diagram according to the equivalent flue length in the table.

The total equivalent flue length is the total length of the flue (including the terminal assembly for vertical flues), plus the resistance of any bends or elbows used.

- equivalent length of 90° elbow is 1 m
- equivalent length of 45° elbow is 0.5 m

- Push the restrictor (1) into the flue connection of the appliance (3)
- Connect the flue/elbow (2) into the flue connection of the appliance (3).

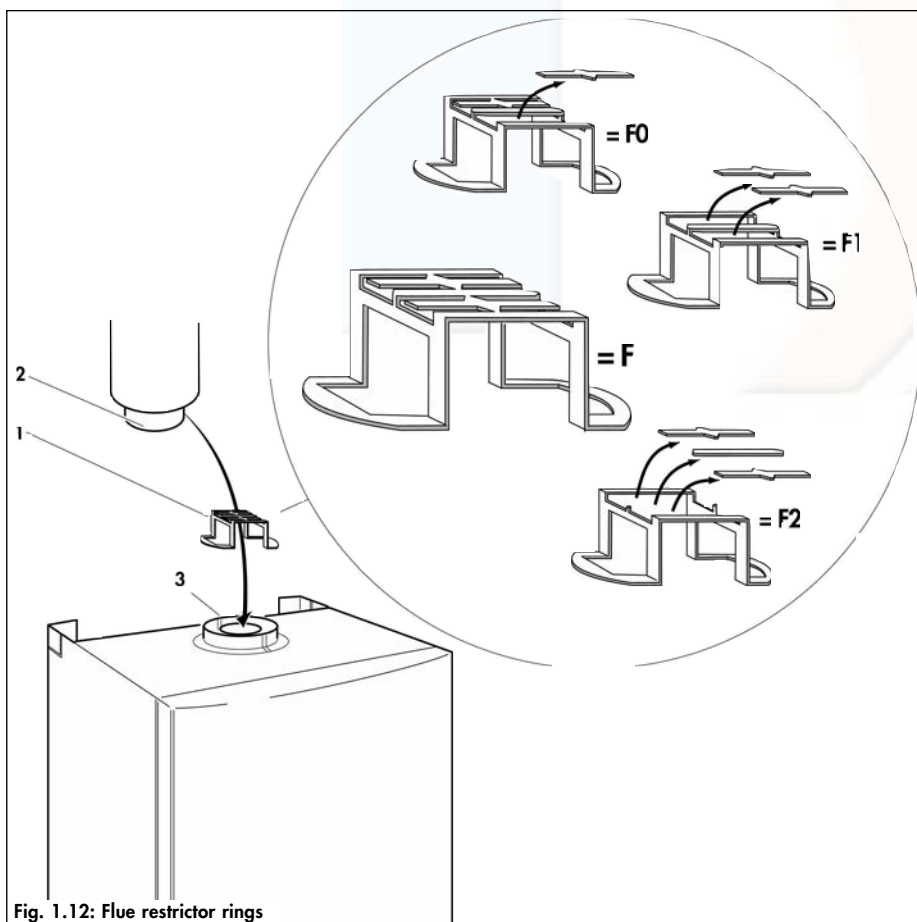
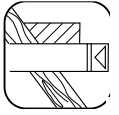

Fig. 1.12: Flue restrictor rings

INSTALLATION OF THE HORIZONTAL AIR/FLUE DUCT (TOP OUTLET)



IMPORTANT:

The flue hole should be cut with a slight fall to outside of 1° to prevent rain water entering the flue.

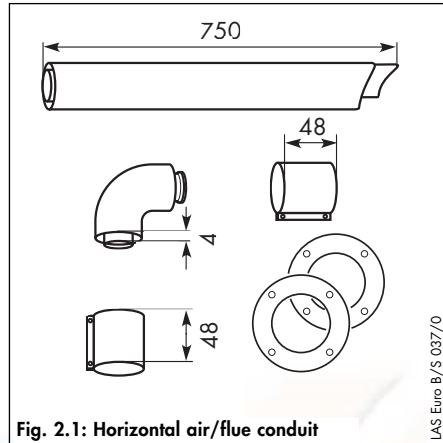

Fig. 2.1: Horizontal air/flue conduit

Horizontal air/flue duct

Accy No.: 303 807 (Length 0.75 m)

Accy No.: 303 806 (telescopic, 0.45 – 0.65 m; turboMAX and thermoCOMPACT only)

Contents of the accessory:

- Horizontal air/flue duct
- 90° elbow
- 2 x 48 mm air duct clamps (3x with telescopic accy.)
- Internal trim ring Ø 100
- External wall seal.

Preparation

- Determine the installation site for the boiler with reference to the installation and servicing instructions supplied with the boiler.
- Ensure that all installation and service clearances are available and that the boiler flue can be installed as detailed in these instructions.
- Fix the paper template, supplied with the boiler, to the wall ensuring that the centreline of the template is vertical using a plumbline or spirit level.

Top outlet flue exiting to rear

- For installations where the air/flue duct is to be installed directly to the rear of the boiler, the installation template details the position of the flue exit hole for horizontal top outlet installation.

Top outlet flue exiting to side

- For installations where the air/flue duct is to be installed to the side, the position of the flue exit hole can be determined by carefully levelling across the wall from the centre line of the air/flue duct hole marked on the template.
- The position of the flue exit hole should allow the flue to be installed with a slight downward slope of about 1° (equivalent to 10 to 15 mm per metre of flue duct). Calculate the required fall according to the flue length and mark the position of the flue exit hole.

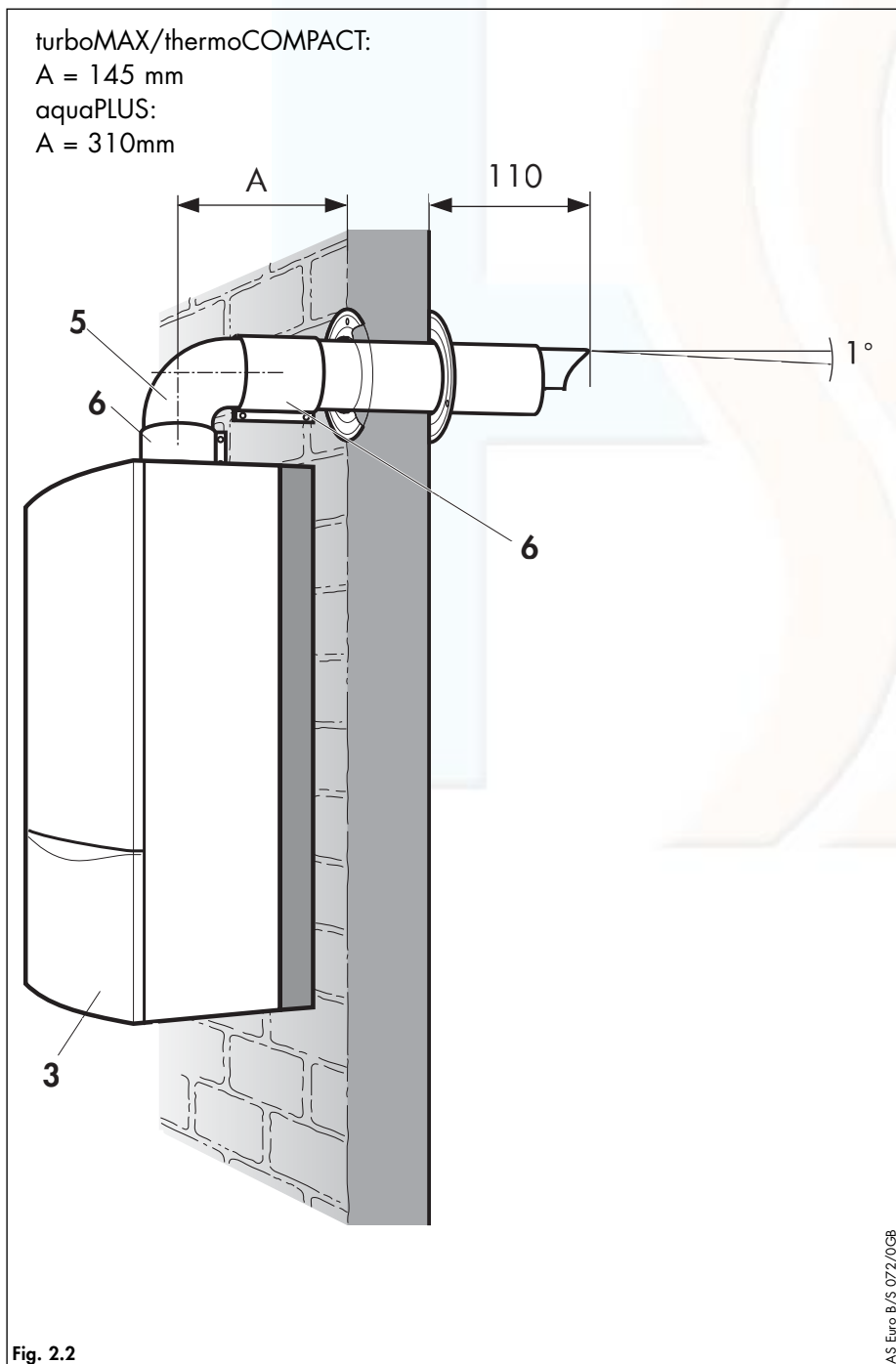
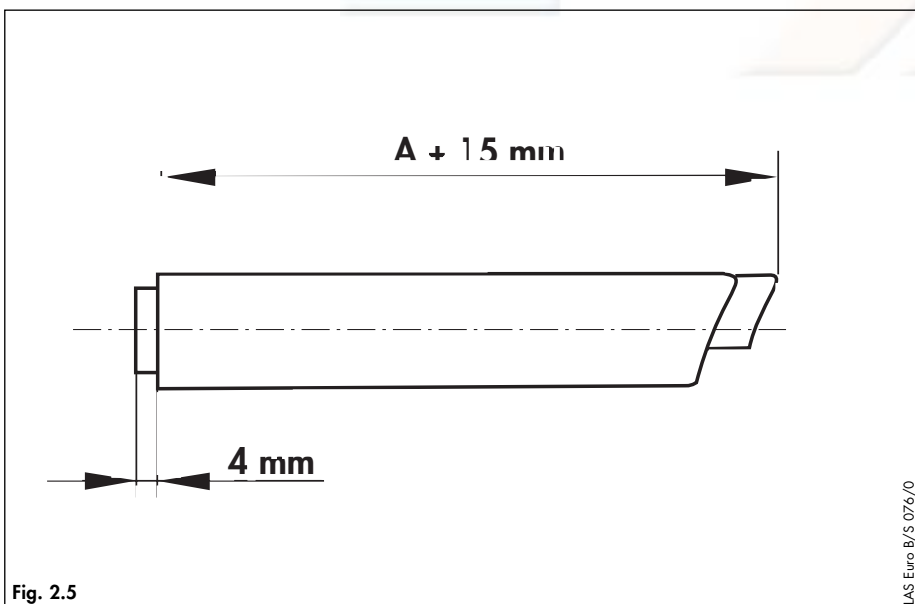
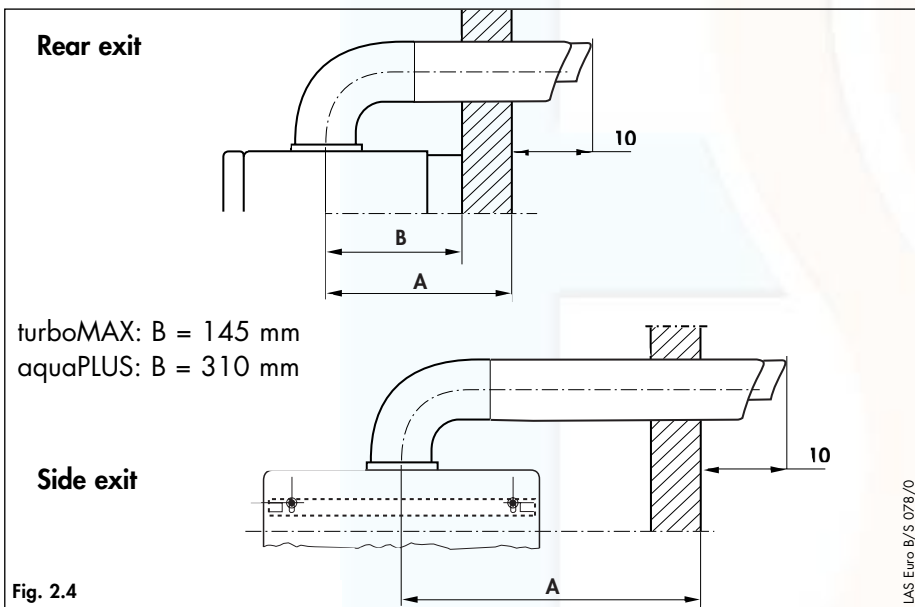
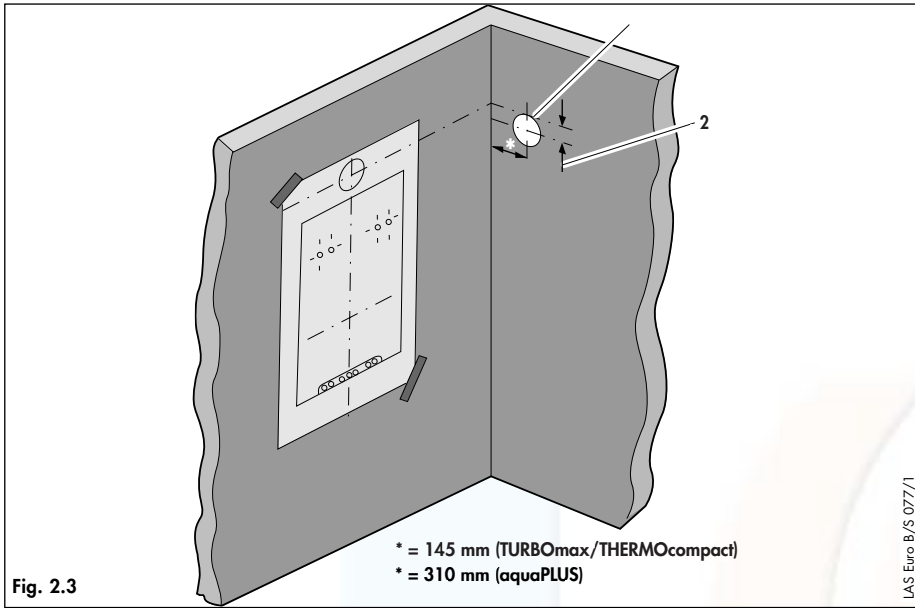

Fig. 2.2



INSTALLATION OF THE HORIZONTAL AIR/FLUE DUCT (TOP OUTLET)



- Once the position of the flue exit hole has been determined, the hole should be cut through the wall using a core drill of 127 mm diameter.

Note: If access can be gained to the proposed flue exit point from outside the dwelling, the hole can be cut with a 107 mm core drill and the flue external wall seal fitted from outside the dwelling.

- Measure the distance from the outside face of the wall to the centre of the fan outlet on the boiler.

This is dimension A.

- (Note: If using the top connection spacer frame accessory with the boilers with a rear exit, make an additional 45 mm allowance for the depth of the frame).
- Cut the air duct and flue duct to the lengths shown in figure 2.4.
- All flue sockets should point towards the terminal.
- When cutting the air and flue ducts it is important to remove any burrs with a file, this ensures easy fitting of the ducts and prevents any rough edges from damaging the flue seals. Care should be taken not to scratch the white surface of the air duct.
- If the installation requires the use of air/flue duct extensions, additional bends or elbows refer to the sections on pages 25 – 27.
- If using the telescopic horizontal air/flue duct and terminal accy. 303806 simply adjust the length as shown in Fig 2.4. Secure the air duct sections together by drilling a 3 mm diameter hole through the location hole in the end of the outer air duct. (Ensure that the drill does not pierce the inner flue duct). Secure the air ducts together using the screw provided.

INSTALLATION OF THE HORIZONTAL AIR/FLUE DUCT (TOP OUTLET)

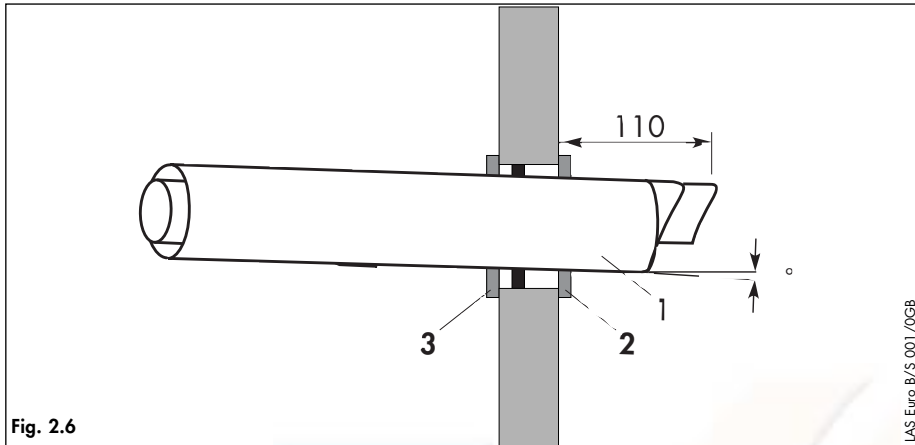
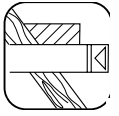

- Push the air/flue duct assembly (1) including the flexible external seal (2) through the wall until the seal clears the outside face of the wall and pull air/flue duct back towards the boiler until the external seal touches the outside wall.
- Ensure that the air/flue duct (1) is centred in the hole and the terminal is correctly positioned with the inlet grille at the bottom.
- Slide the internal trim ring (3) over the air duct until it is flush with the wall.
- At this stage it is necessary to prepare and fit the boiler onto the hanging bracket – refer to the boiler installation instructions.
- Before installing the flue elbow onto the boiler flue outlet select and fit the correct restrictor ring (page 10) into the bottom of the boiler elbow.
- Fit the elbow to the boiler by inserting the spigot of the flue elbow into the flue socket on the boiler and secure using the air duct clamp provided.
- Pull the air/flue duct back through the wall such that the flue duct fully engages into the flue elbow socket.
- Fit the air duct clamp ensuring that it is positioned centrally.
- Drill two holes 3 mm Ø through the air duct of both the elbow/flue and elbow/boiler clamps at the most convenient holes on the air duct clamps. (Ensure that the drill does not penetrate the inner flue duct). Screw the clamps to the air ducts of the flue assembly, the elbow and boiler using the screws supplied.
- Slide the internal trim ring back to the wall, securing in position with a small amount of sealant if required.



INSTALLATION OF THE HORIZONTAL AIR/FLUE DUCT (REAR OUTLET) (TURBOMAX AND THERMOCOMPACT ONLY)

IMPORTANT:

The flue hole should be cut with a slight fall to outside of 1° to prevent rain water entering the flue. Minimum top clearance for rear installation is 100 mm.

IMPORTANT:

To install this accessory access must be available to the proposed flue exit point outside the dwelling.

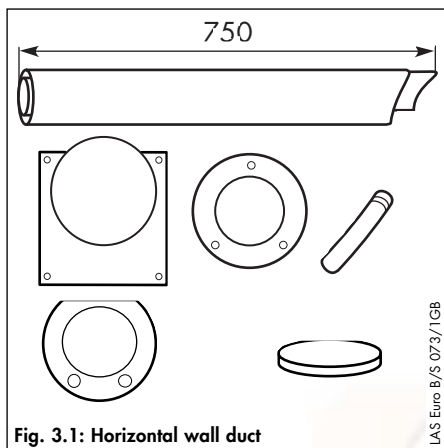

Fig. 3.1: Horizontal wall duct

Rear outlet flue accessory

Accy No: 303 817

Contents of the accessory

- Rear air/flue duct
- Flue securing collar Ø 100 including fixing screws and wall plugs
- Air duct connection piece and screws
- Flue cap
- Rubber bung
- Air pressure tube extension and connecting nipple

Preparation

- Determine the installation site for the boiler with reference to the installation and servicing instructions supplied with the boiler.
- Ensure that all installation and service clearances are available and that the boiler flue can be installed as detailed in these instructions.
- Fix the paper template, supplied with the boiler, to the wall ensuring that the centreline of the template is vertical using a plumbline or spirit level.
- The installation template details the position of the flue exit hole for rear outlet installations. Ensure that the correct flue exit hole has been identified.
- Once the position of the flue exit hole has been determined, the hole should be cut through the wall using a core drill of 107 mm diameter.
- Measure the thickness of the wall through which the flue will pass. **This is dimension C.**
- (Note: If using the top connection spacer frame accessory make an additional 45 mm allowance for the depth of the frame).
- Cut the air duct and flue duct to the lengths shown in figure 3.2.
- When cutting the air and flue ducts it is important to remove any burrs with a file, this ensures easy fitting of the ducts.

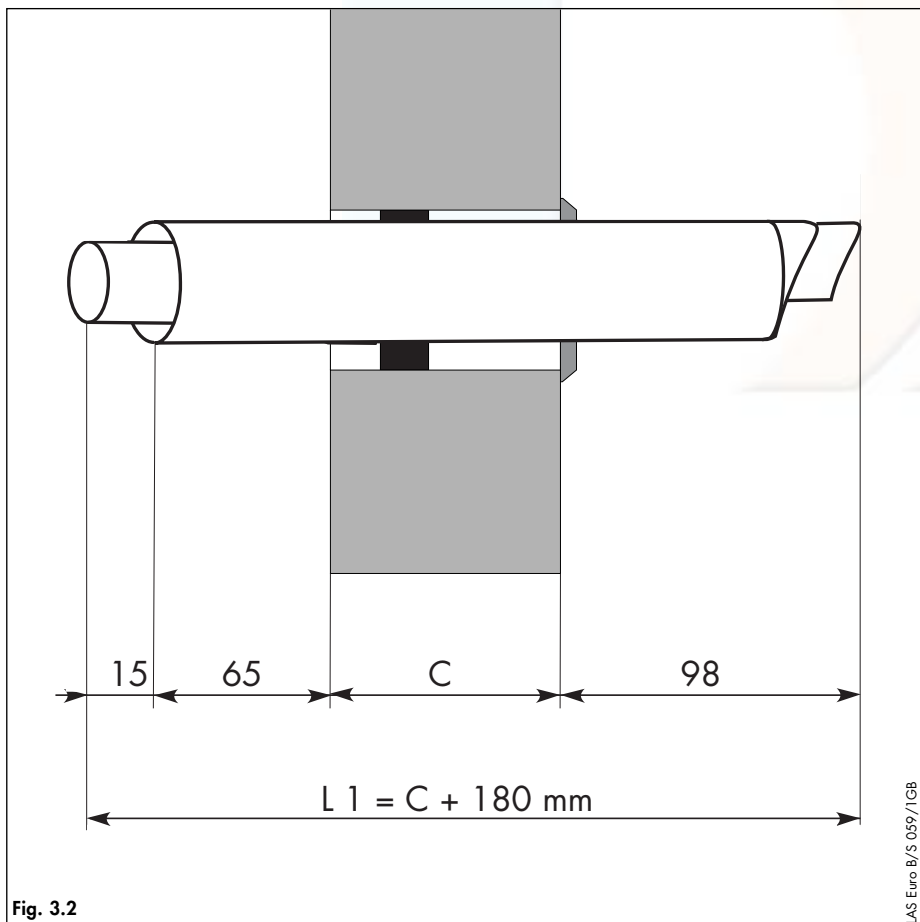

Fig. 3.2

INSTALLATION OF THE HORIZONTAL AIR/FLUE DUCT (REAR OUTLET) (TURBOMAX AND THERMOCOMPACT ONLY)

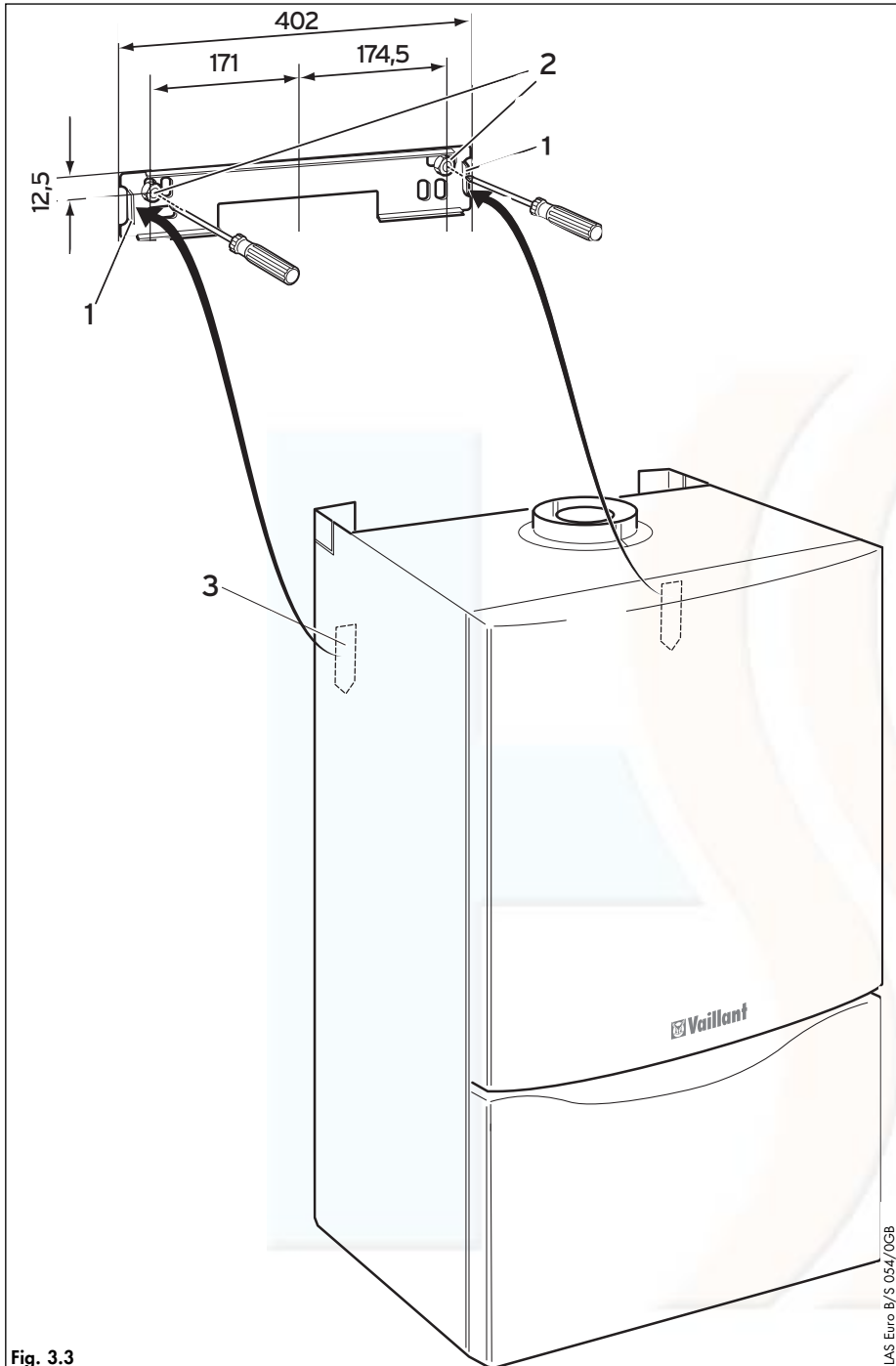
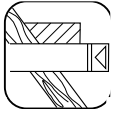
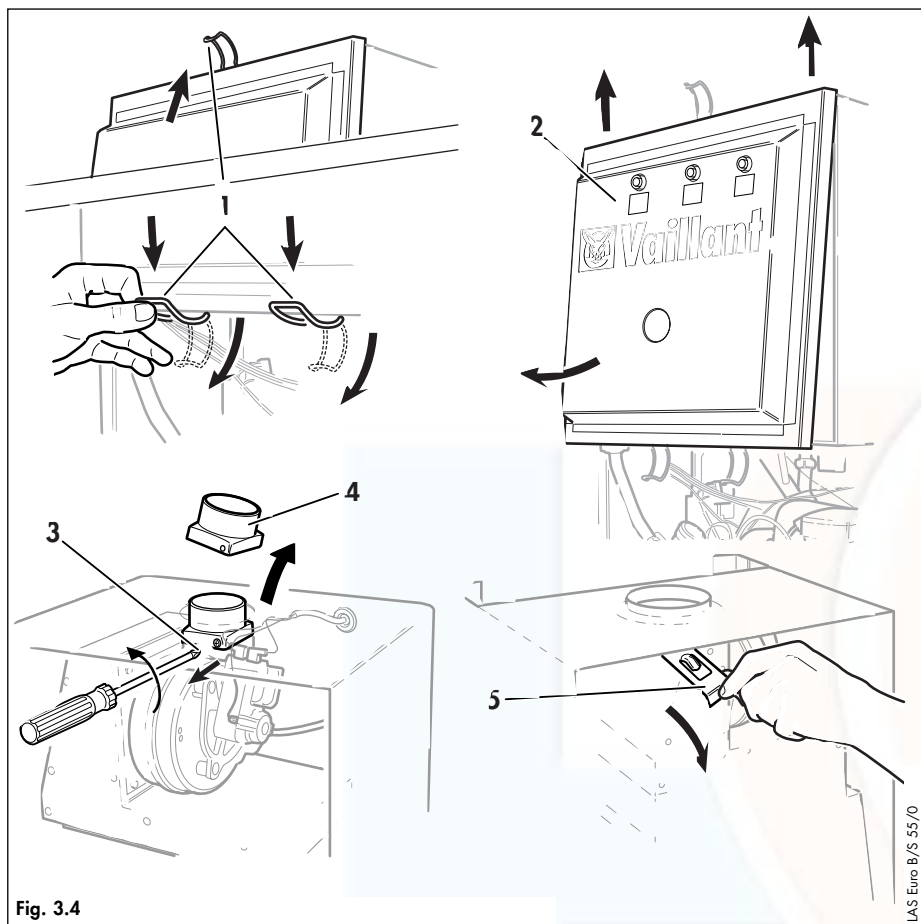

Fig. 3.3

- Secure the boiler hanging bracket (1) to the wall using the screws provided (2).
- At this stage it is necessary to prepare and fit the boiler onto the hanging bracket – refer to the boiler installation instructions.

INSTALLATION OF THE HORIZONTAL AIR/FLUE DUCT (REAR OUTLET) (TURBOMAX AND THERMOCOMPACT ONLY)



Preparation of boiler for rear outlet air/flue duct

For thermoCOMPACT 615, 637 and turboMAX plus 837:

- Remove boiler case as detailed in the installation instructions supplied with the boiler.
- Release the three clamps (1) and remove the combustion chamber cover (2).
- Loosen the screw (3) and remove the flue gas connector (4) from the fan.
- Remove the retaining spring (5).

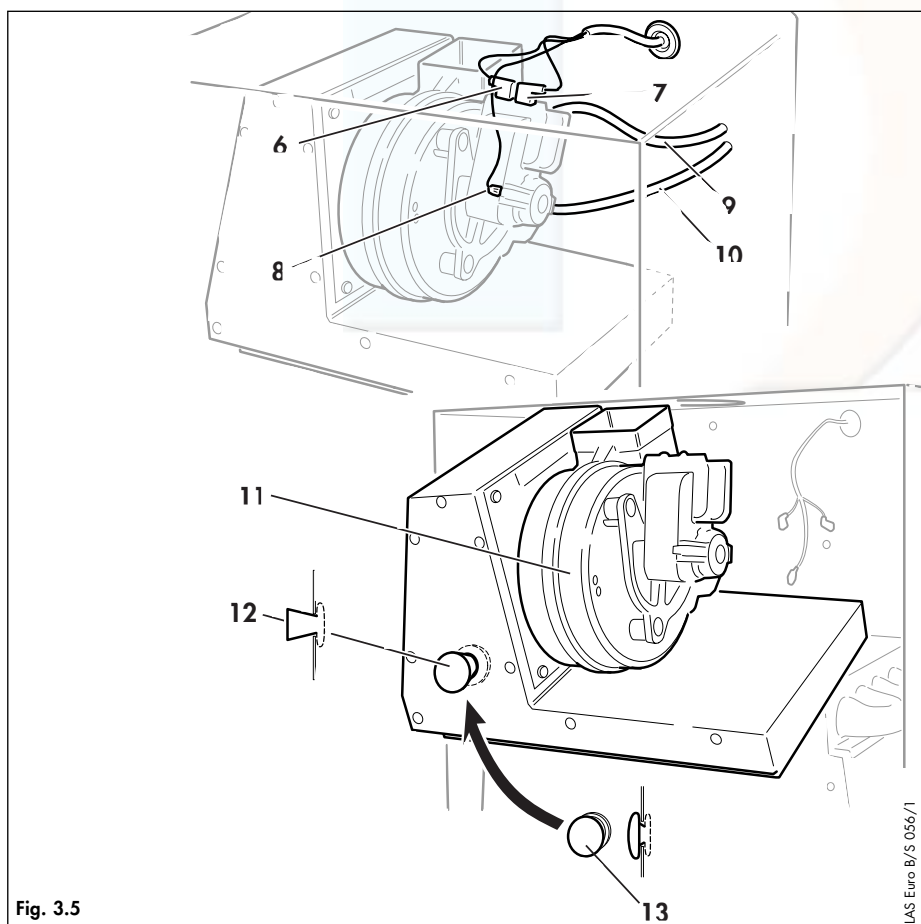

- Pull the cables and two tubes (9, 10) from the fan assembly. Please ensure that you note the respective connection points for each tube.
- Remove the complete fan assembly (11) from the boiler.
- Remove the rubber funnel (12) and place to side.
- Seal the hole with the rubber bung (13) provided.

INSTALLATION OF THE HORIZONTAL AIR/FLUE DUCT (REAR OUTLET) (TURBOMAX AND THERMOCOMPACT ONLY)

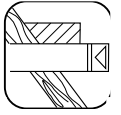

Preparation of boiler for rear outlet air/flue duct

For thermoCOMPACT 620, 624, 628, turboMAX pro 24, 28 and turboMAX plus 824, 828:

- Remove boiler case as detailed in the installation instructions supplied with the boiler.
- Release the three clamps (1) and remove the combustion chamber cover (2).
- Remove the screw (3).
- Pull the two cables (8) and two tubes (9) from the fan assembly. Please ensure that you note the respective connection points for each tube.
- Remove the fan (10) from the collector hood by pushing downwards to unlock.
- Remove collector hood from the boiler
- Remove the rubber funnel (12).
- Seal the hole with the rubber bung (13) provided.

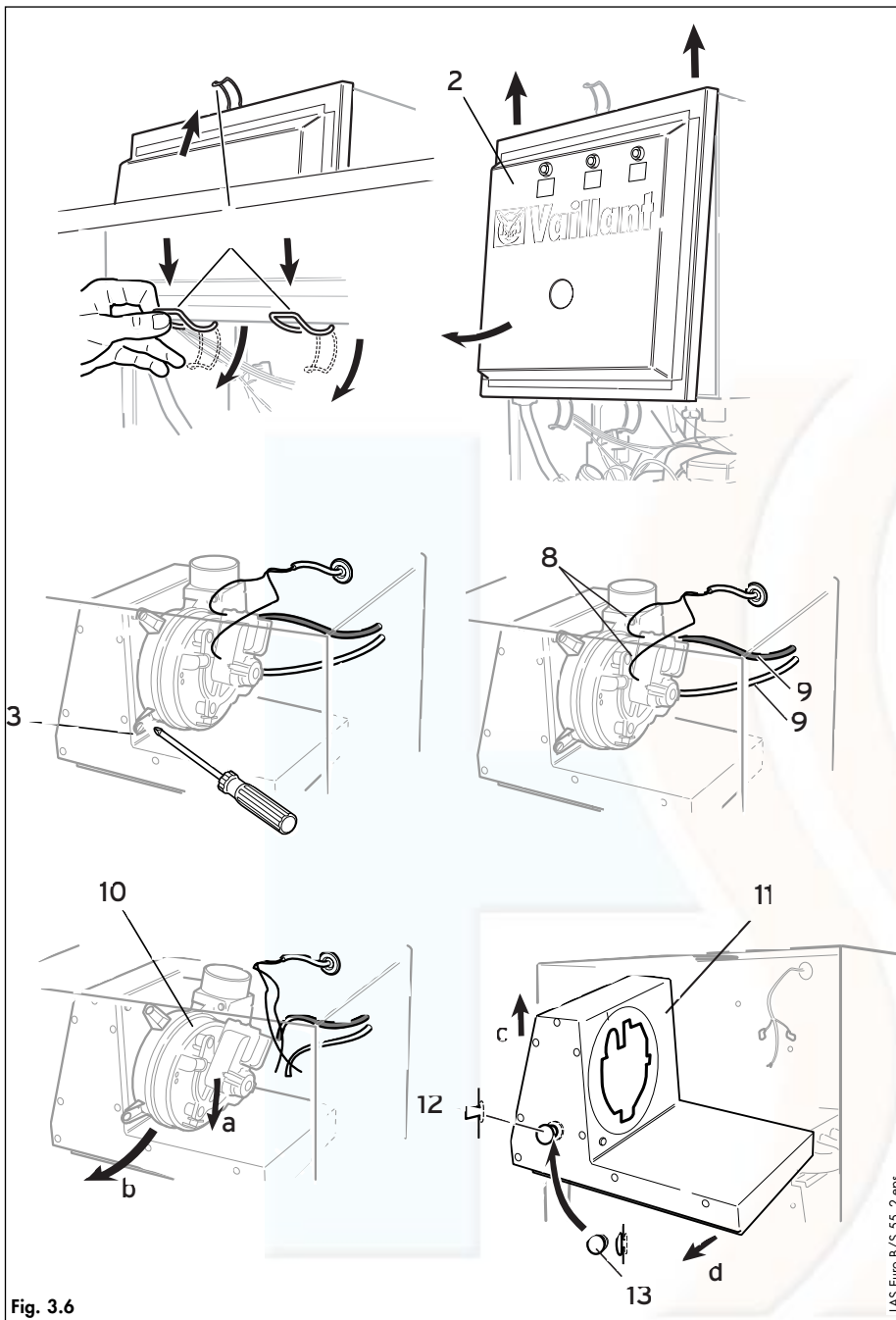

Fig. 3.6

LAS Euro B/S 55_2.eps

PART 1 CONCENTRIC 60/100

INSTALLATION OF THE HORIZONTAL AIR/FLUE DUCT (REAR OUTLET)

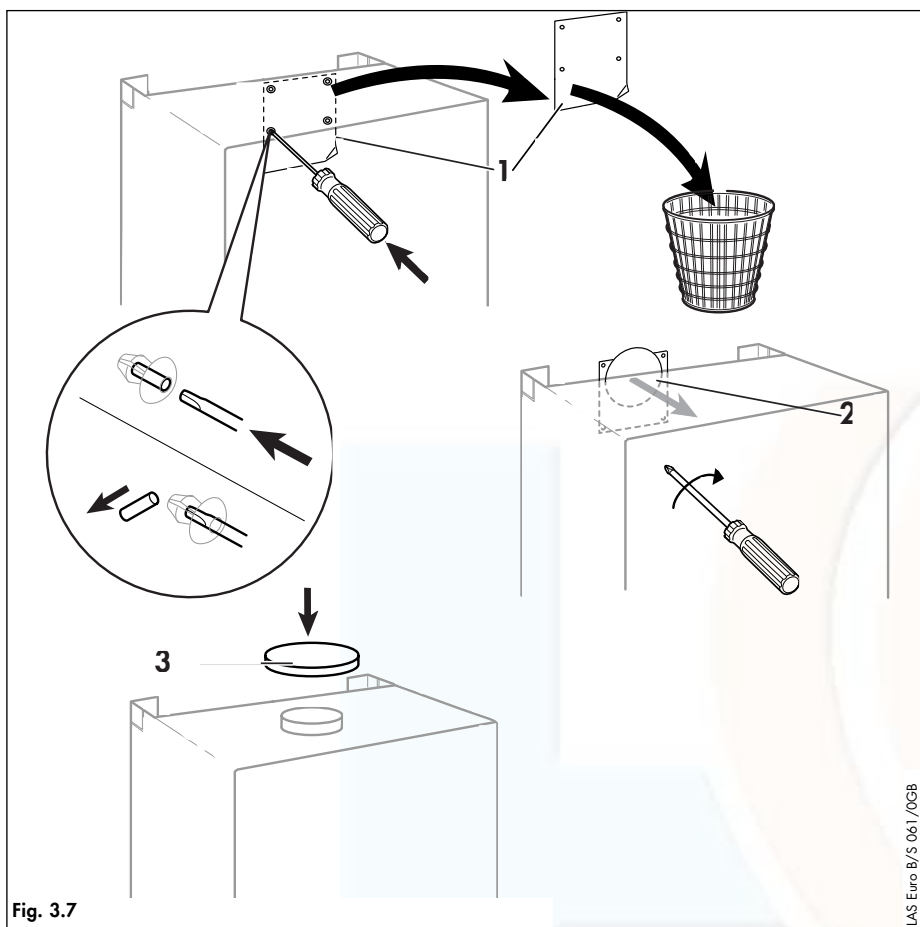
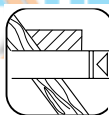

Fig. 3.7

LAS Euro B/S 061 /0GB

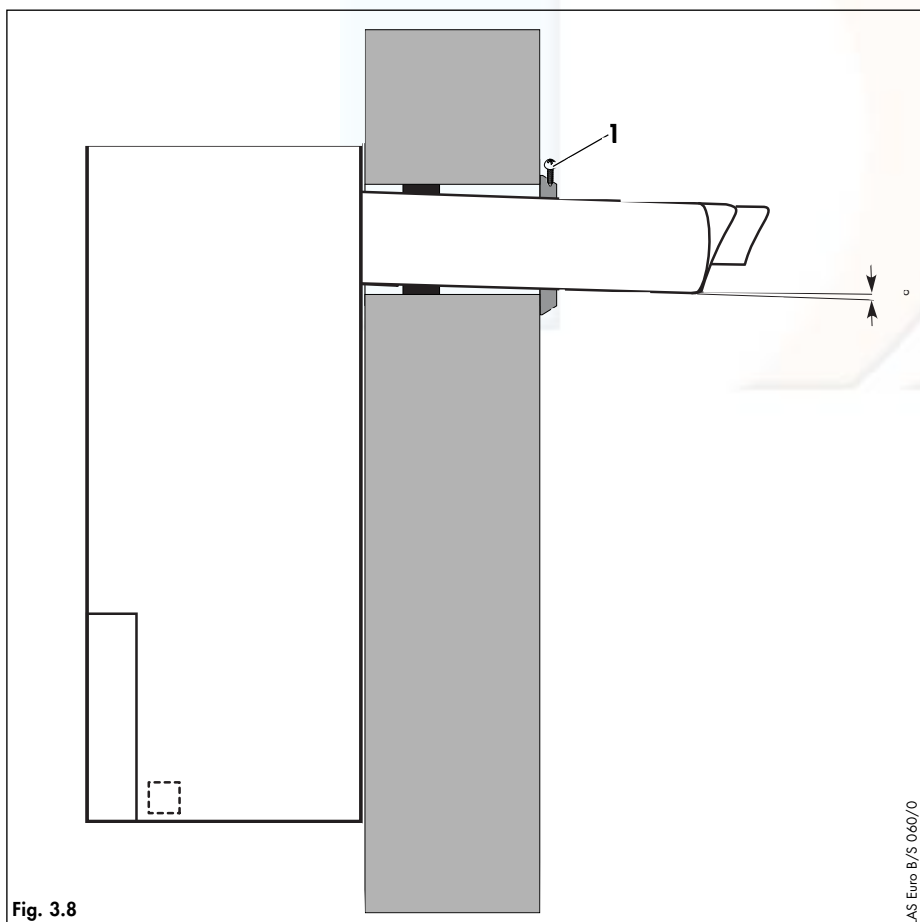

Fig. 3.8

LAS Euro B/S 060/0

- Remove the metal plate (1) covering the rear flue outlet point by pushing through the centre pins of the plastic fasteners as shown in the drawing. Now remove the metal plate by pulling on the folded tag of the plate.
- Fit the air duct connection piece (2) to the back of the boiler at the rear flue outlet point with the four screws provided.
- Push the flue cap (3) firmly into position to seal the top flue outlet.
- From outside the dwelling locate the flue securing collar centrally over the flue exit hole, mark and drill the three holes and insert the wall plugs provided.
- Push the flue securing collar on to the flue at the opposite end to the terminal, ensure that the flue securing collar is fitted with the holes for securing the collar to the air duct facing outside.
- Push the air/flue duct assembly through the wall from outside the dwelling.
- If the internal trim ring is to be used, position it over the end of the air duct from inside the dwelling.
- Engage the end of the air duct into the air duct connection piece at the rear of the boiler. Now from outside the dwelling push the entire air/flue duct in towards the boiler such that the air duct completely engages all the way into the air duct connection on the boiler. Ensure that the flue terminal is correctly positioned with the hood at the top and the air inlet at the bottom.

Important:

- **Fix the flue securing collar to the wall with the three screws provided into the wall plugs previously installed.**
- **Drill three 3mm Ø holes through the air duct using the pre drilled holes in the collar as a guide. Secure the collar to the air duct with the three screws (1) provided.**
- From inside the dwelling slide the internal trim ring back to the wall and secure in position.
- Fit the correct restrictor ring (page 10 of the flue instructions provided with the boiler) into the end of the

INSTALLATION OF THE HORIZONTAL AIR/FLUE DUCT (REAR OUTLET) (TURBOMAX AND THERMOCOMPACT ONLY)

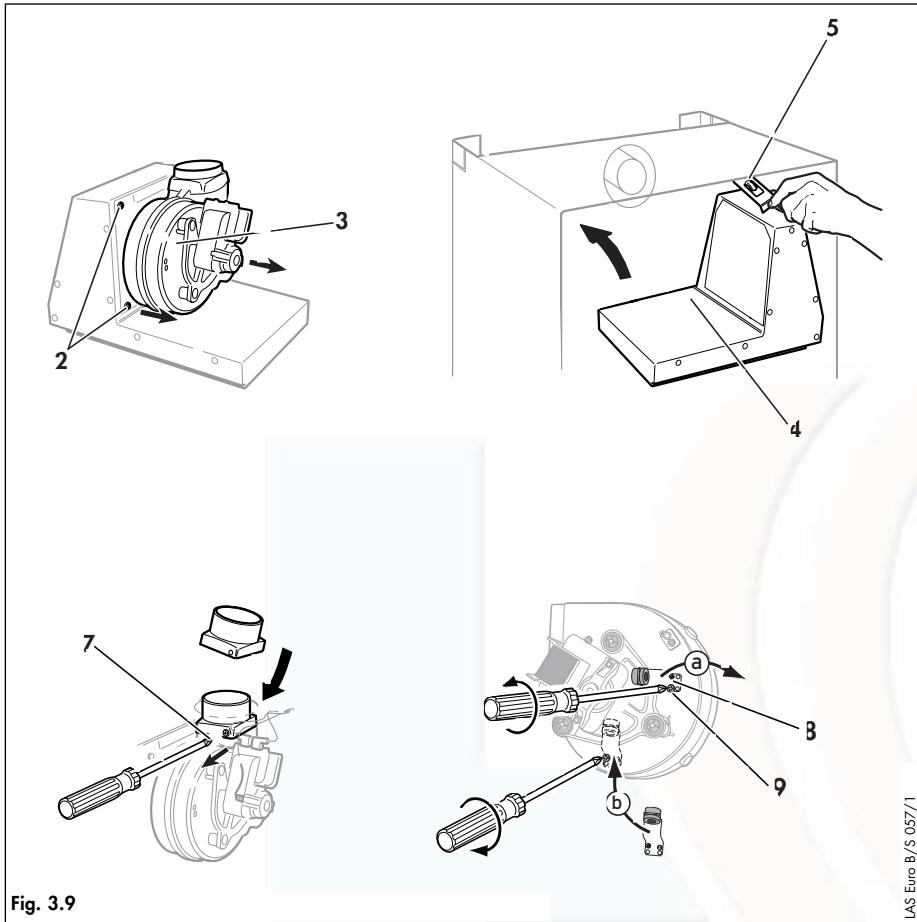
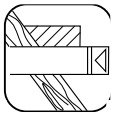

Fig. 3.9

LAS Euro B/S 057/1

For thermoCOMPACT 615, 637 and turboMAX plus 837:

- Remove two screws (2) and separate the fan from the collector hood (4).
- Swivel the collector hood (4) through 180° and locate back into position in the appliance.
- Extend the white air pressure tube with the tube extension and nipple provided.
- Refit the retaining spring clip (5) on the top of the collector hood (4). Remove blank and refit funnel.
- Loosen the screw (9) and remove the support bracket (8).
- Reconnect the bracket into position (b).
- Refit the flue gas connector (6) to the fan (7) and secure.

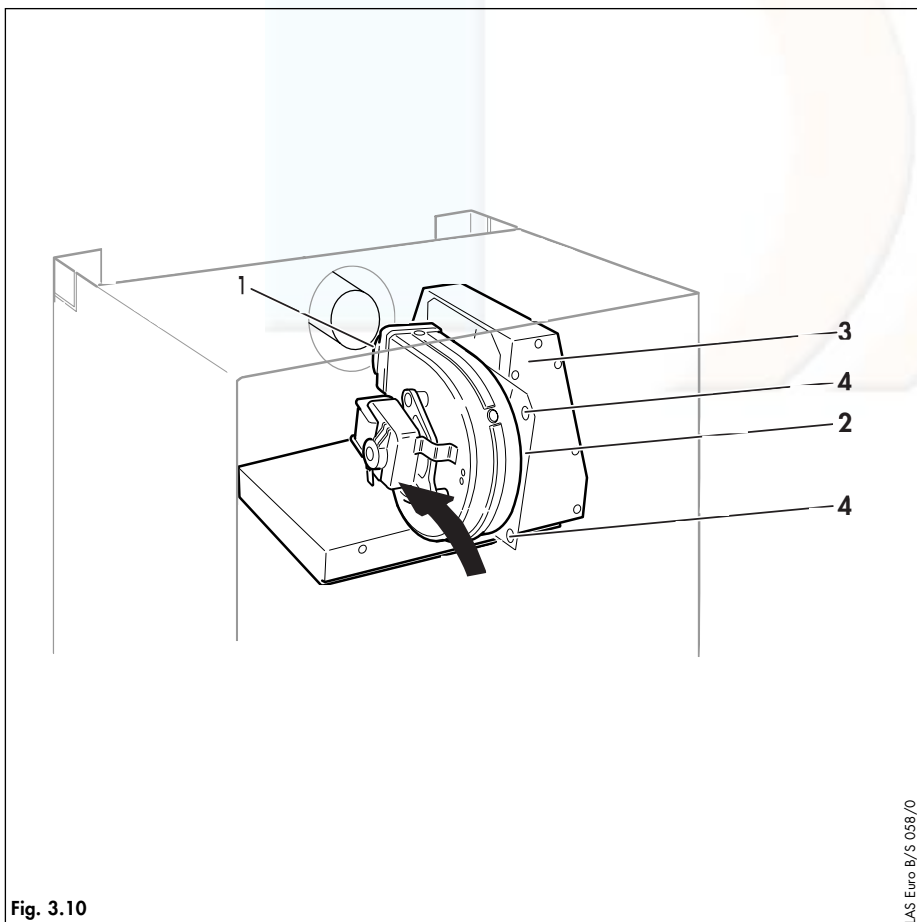

Fig. 3.10

LAS Euro B/S 058/0

- Reconnect the electrical cables to the fan.
- Gently push the flue duct downwards to the left.
- Slide the fan (2) into position on flue collector hood (3). Ensure that the flue gas connector (1) engages over the end of the flue duct and the flange on the back of the fan plate locks in to the collector hood.
- Secure the fan to the flue collector hood using the two screws (4).
- Reconnect the air pressure tubes to the fan, ensuring that the air tubes are connected to the correct nipple.

Note: Blue tube connects to the rear most fan outlet spigot.

- On combustion chamber cover front swap top left hand rubber bung with the metal hole bung.
- Reassemble the boiler in reverse order.
- Complete the installation as detailed in the boiler Installation and Servicing instructions.

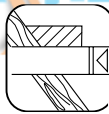

INSTALLATION OF THE HORIZONTAL AIR/FLUE DUCT (REAR OUTLET) (TURBOMAX AND THERMOCOMPACT ONLY)

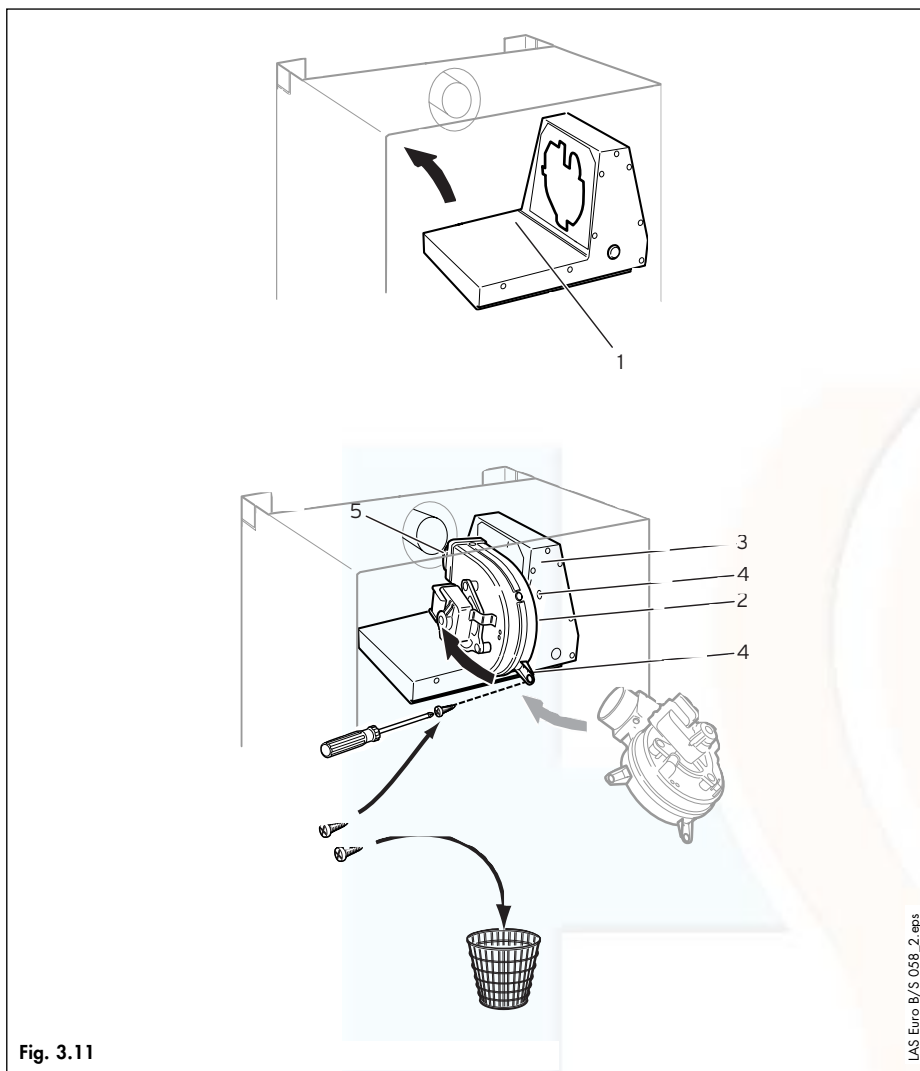

Fig. 3.11

For thermoCOMPACT 620, 624, 628, turboMAX pro 24, 28, turboMAX plus 824, 828:

- Refit the collector hood (1). Remove blank and refit funnel.
- Reconnect the electrical cables to the fan.
- Gently push the flue duct downwards to the left.
- Slide the fan (2) into position on flue collector hood (3). Ensure that the flue gas connector (5) engages over the end of the flue duct and the flange on the back of the fan plate locks in to the collector hood.
- Secure the fan to the flue collector hood using only one screw (4).
- Reconnect the air pressure tubes to the fan, ensuring that the air tubes are connected to the correct nipple.

Note: Blue tube connects to the rear most fan outlet spigot.

- On combustion chamber cover front swap top left hand rubber bung with the metal hole bung.
- Reassemble the boiler in reverse order.
- Complete the installation as detailed in the boiler Installation and Servicing instructions.



IMPORTANT:

The flue hole should be cut with a slight fall towards the Se-duct of 1°.

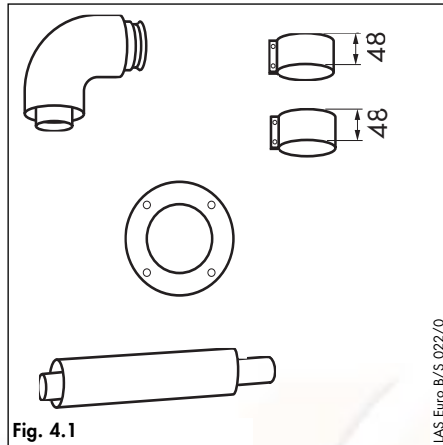

Fig. 4.1

Se-duct flue

Accy No.: 303 810

Contents of the accessory:

- Horizontal air/flue duct
- 90°elbow
- 2 x 48 mm air duct clamps
- Internal trim ring
- Screws

Preparation

- Determine the installation site for the boiler with reference to the installation and servicing instructions supplied with the boiler and also any requirements of the Se-duct manufacturer.
- Ensure that all installation and service clearances are available and that the boiler flue can be installed as detailed in these instructions.
- Fix the paper template, supplied with the boiler, to the wall ensuring that the centreline of the template is vertical using a plumbline or spirit level.

turboMAX/thermoCOMPACT:
 A = 145 mm
 aquaPLUS:
 A = 310 mm

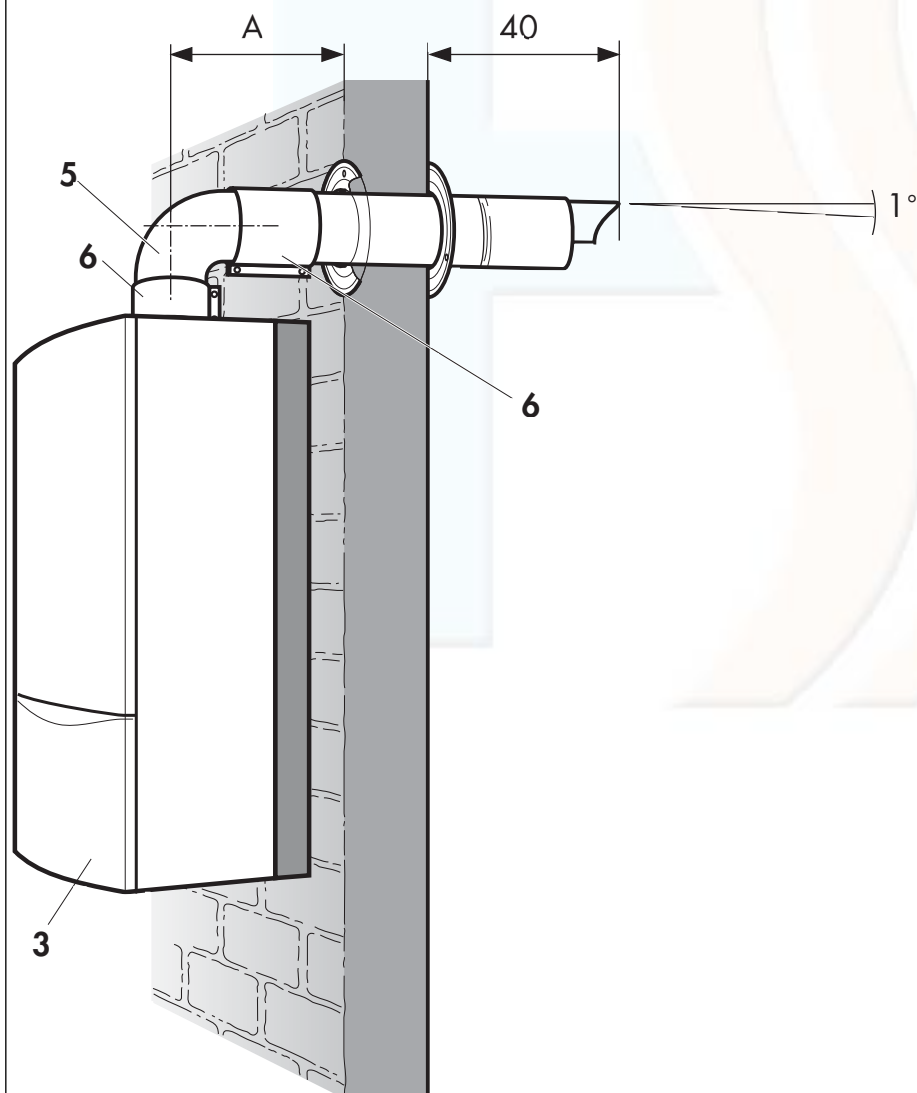

Fig. 4.1a

Top outlet flue exiting to rear

- For installations where the air/flue duct is to be installed directly to the rear of the boiler, the installation template details the position of the flue exit hole for horizontal top outlet installation.

Top outlet flue exiting to side

- For installations where the air/flue duct is to be installed to the side, the position of the flue exit hole can be determined by carefully levelling across the wall from the centre line of the air/flue duct hole marked on the template.
- The position of the flue exit hole should allow the flue to be installed with a slight downward slope of about 1° (equivalent to 10 to 15 mm per metre of flue duct). Calculate the required fall according to the flue length and mark the position of the flue exit hole.

LAS Euro B/S 072/068

PART 1 CONCENTRIC 60/100

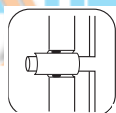

2 INSTALLATION OF THE SE-DUCT FLUE

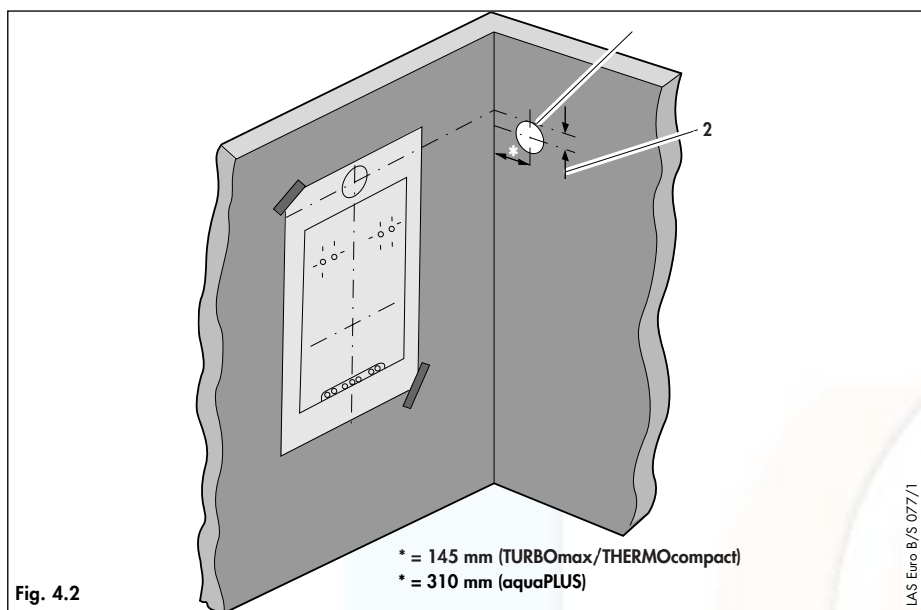

- Once the position of the flue exit hole has been determined, the hole should be cut through the wall using a core drill of 120 mm diameter. Ensure no debris enters the Se-duct.
- Measure the distance from the wall face (inside of the duct) to the centre of the fan outlet on the boiler.

This is dimension D.

- (Note: If using the top connection spacer frame accessory with the boilers with a rear exit, make an additional 45 mm allowance for the depth of the frame).

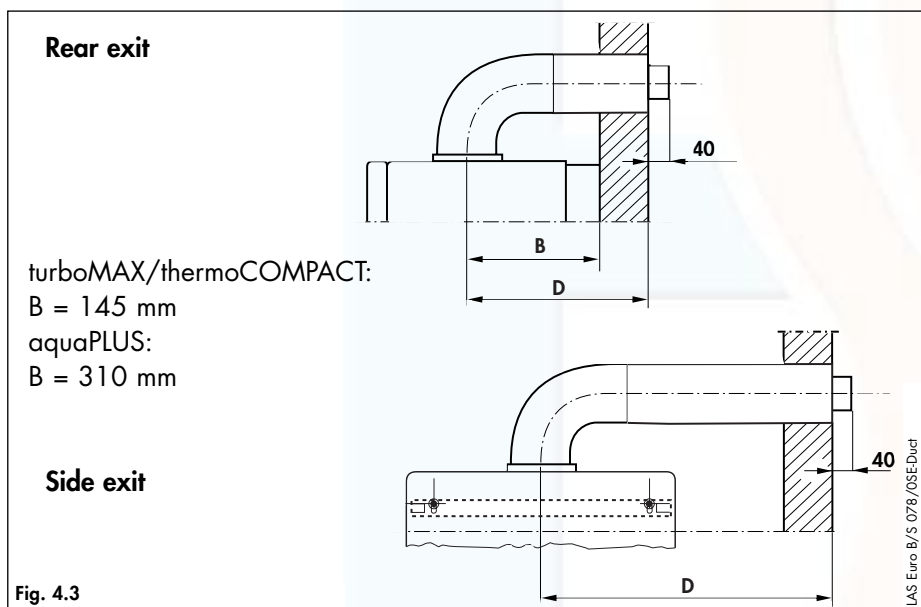

Length of Air duct:

- Cut the length of the air duct as follows:
Length of air duct = D - 95 mm

Length of Flue duct:

- Cut the length of the flue duct as follows:
Length of flue duct = Length of air duct + 44 mm

- All flue sockets should point towards the terminal.
 - Ensure that the flue duct protrudes by 40 mm into the Se-duct.
 - When cutting the air and flue ducts it is important to remove any burrs with a file, this ensures easy fitting of the ducts and prevents any rough edges from damaging the flue seals.
- Care should be taken not to scratch the white surface of the air duct.

- If the installation requires the use of air/flue duct extensions, additional bends or elbows refer to the sections on pages 25 – 27.

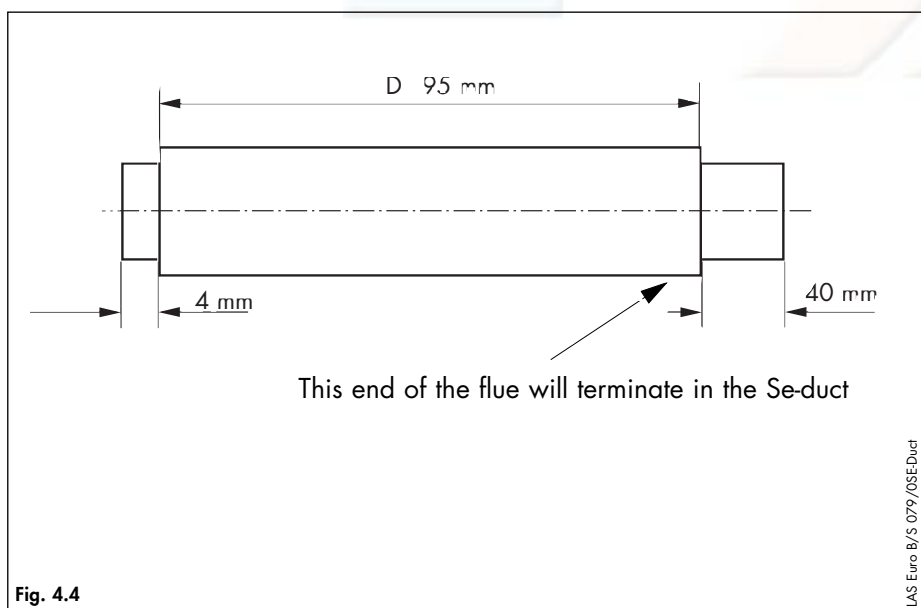

INSTALLATION OF THE SE-DUCT FLUE

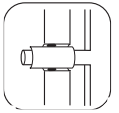

- Insert the end of the air/flue duct assembly through the se-duct wall.
- Slide internal trim ring over the air duct until it is flush with the wall.
- At this stage it is necessary to prepare and fit the boiler onto the hanging bracket – refer to the boiler installation instructions.
- Before installing the flue elbow onto the boiler flue outlet select and fit the correct restrictor ring (page 10) into the bottom of the boiler elbow.
- Fit the elbow to the boiler by inserting the spigot of the flue elbow into the flue socket on the boiler and secure using the air duct clamp provided.
- Pull the air/flue duct back through the se-duct wall such that the flue duct fully engages into the flue elbow socket.
- Fit the air duct clamp ensuring that it is positioned centrally.
- Drill two holes 3 mm Ø through the air duct of both the elbow/flue and elbow/boiler clamps at the most convenient holes on the air duct clamps. (Ensure that the drill does not penetrate the inner flue duct). Screw the clamps to the air ducts of the flue assembly, the elbow and boiler using the screws supplied.
- Slide the internal trim ring back to the wall and seal and secure in position.



2 INSTALLATION OF THE VERTICAL AIR/FLUE DUCT

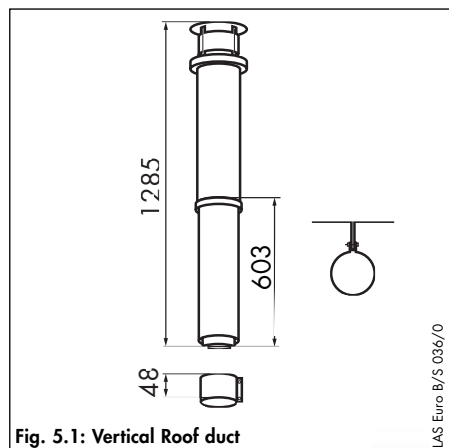

Vertical air/flue duct

Accy. Vaillant Part No.: 303 800

Contents of the accessory:

- Vertical air/flue duct and terminal assembly
- 48 mm air duct clamp
- Fixing bracket

The air/flue duct assembly may be connected directly to the flue outlet on top of the boiler.

In addition to the vertical air/flue duct and terminal accessory, air/flue duct extensions can be added to increase the length of the flue.

Preparation

- Determine the installation site for the boiler with reference to the installation and servicing instructions supplied with the boiler.
- Ensure that all installation and service clearances are available and that the boiler flue can be installed as detailed in these instructions.
- Determine the point where the vertical air/flue duct and terminal assembly will penetrate the roof.

Please note: The vertical air/flue duct and terminal accessory (Accy. No. 303 800) may be shortened. The outer 'white' duct should be shortened first, then the inner flue duct cut so that it protrudes 4 mm out of the air duct. In case of installation directly to the boiler without elbows or bends, it is essential that the roof tile/collar is vertically aligned with the air/flue duct of the boiler.

Pitched roof

- Determine the point of termination of the vertical air/flue duct and terminal assembly. Install the adjustable pitched roof tile (1, fig. 5.2) in position.
- Fit the adjustable hood over the roof tile according to the roof pitch. The adjustable hood is suitable for roof pitches from 25° to 35°, or 35° to 45° by reversing.

Flat roof

- Determine the point of termination of the vertical air/flue duct and terminal assembly.
- Make a hole in the roof of 120 mm diameter. Secure the flat roof collar (1, fig. 5.2) to the roof covering above the hole in accordance with the codes of practice for flat roofs (CP 144) to ensure a watertight seal.

Pitched and flat roof installations

- From above insert the air/flue duct and terminal assembly (5) into the adjustable roof tile (pitched roof) or roof penetration collar (flat roof) until it is fully seated. Adjust the vertical alignment of the air/flue duct and terminal assembly and secure the air duct with the fixing bracket provided (6).
- At this stage it is necessary to prepare and fit the boiler onto the hanging bracket – refer to the boiler installation instructions.
- If the installation requires the use of air/flue duct extensions, additional bends or elbows please refer to the sections on pages 25 – 27.

INSTALLATION OF THE VERTICAL AIR/FLUE DUCT

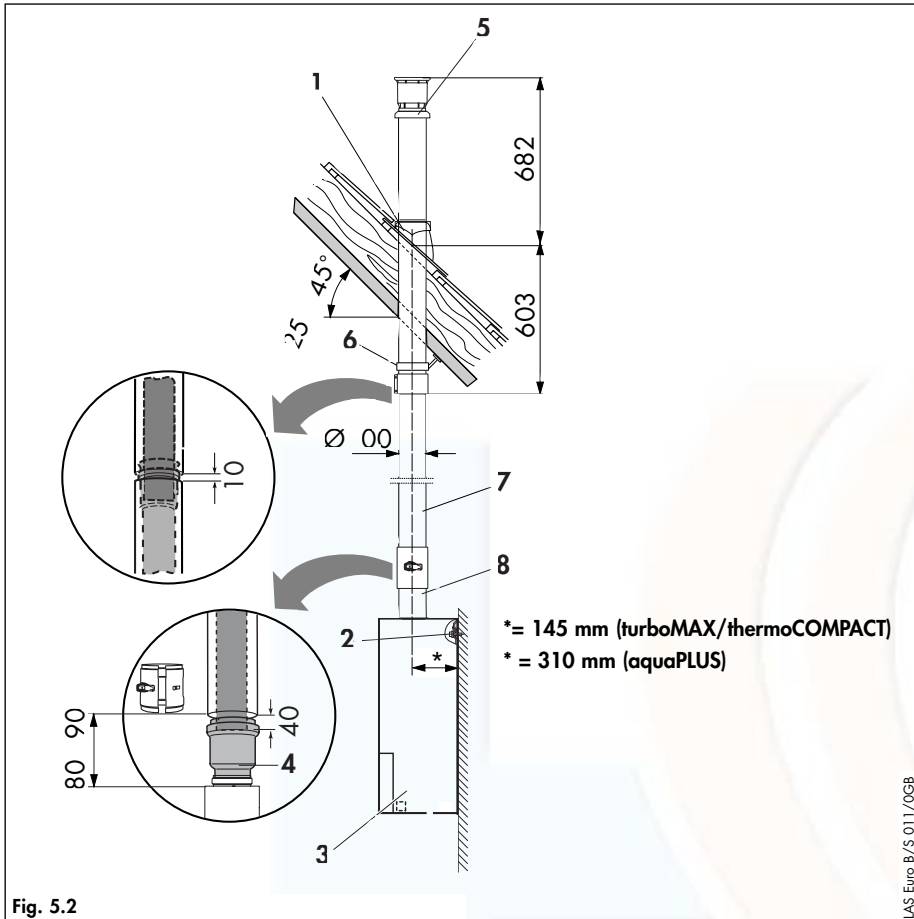
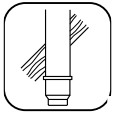

- If the vertical air/flue duct and terminal assembly is to be connected directly to the boiler, it will be necessary to temporarily raise the flue slightly in order to mount the boiler.
- Before connecting the flue on to the boiler flue outlet select and fit the correct restrictor ring into the bottom of the flue (as detailed in these installation instructions).
- Fit the air duct clamp over the air duct.
- Connect the air/flue duct to the boiler by inserting the spigot of the air/flue duct into the flue socket on the boiler and secure using the air duct clamp.
- Drill two holes 3 mm \varnothing through the air duct of the flue/boiler clamp at the most convenient holes on the air duct clamp. (Ensure that the drill does not penetrate the inner flue duct). Screw the clamp to the air ducts of the flue assembly and the boiler using the screws supplied.
- Ensure that any air duct clamps used are positioned centrally and fixed to the air duct using the self tapping screws supplied.
- **Note:** The air/duct clamp must not be screwed to the bottom of the vertical air/flue duct and terminal accessory to allow for any slight movement in the roof structure.
- Ensure that at least one pipe clamp supports the air/flue duct at each extension fitted.

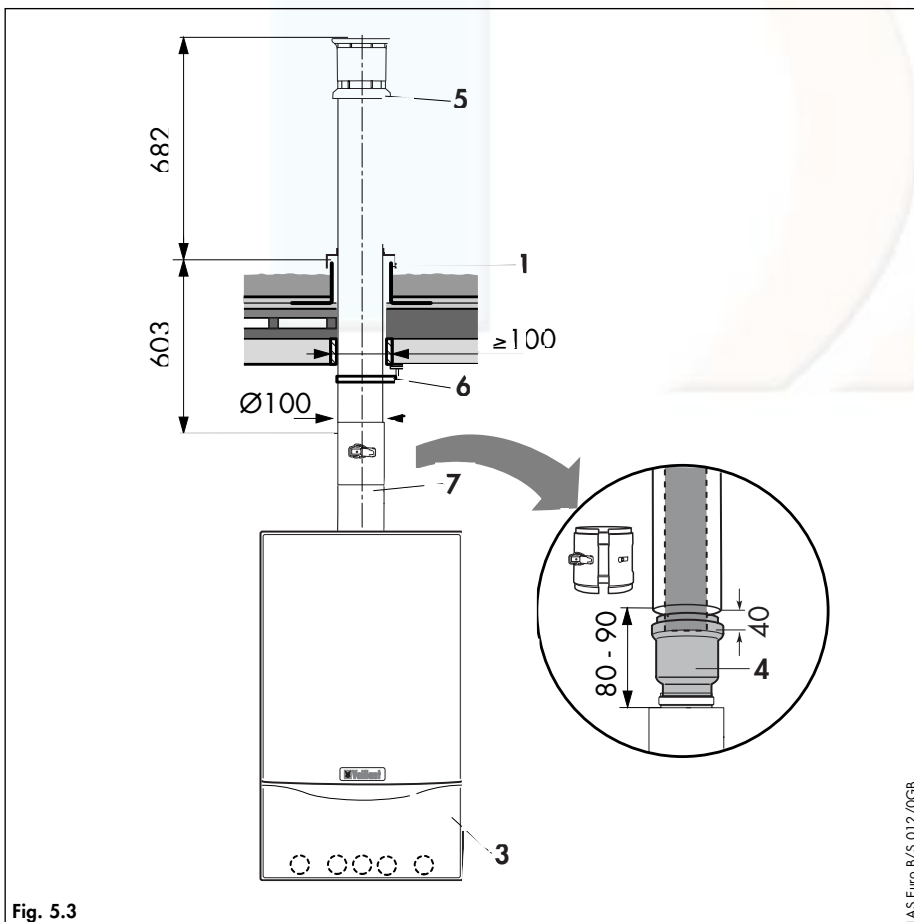



FITTING AIR/DUCT EXTENSIONS

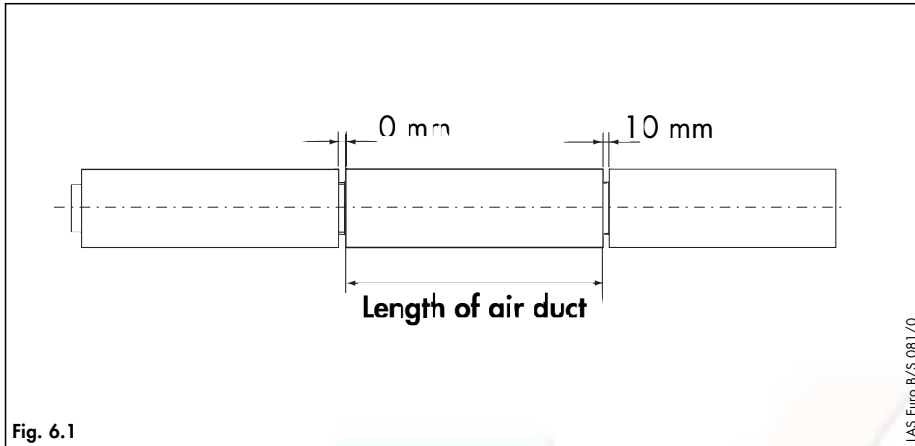

Fitting extensions

- Measure and note the length of the air duct extension required for the installation.

Use this measurement to calculate the length to cut the air and flue ducts:

Length of Air duct

- Cut the length of the air duct as follows:
Length of air duct as shown in Fig. 6.1

Note: Minimum length of air duct is 100 mm.

Length of Flue duct

- Cut the length of the flue duct as follows:
Length of flue duct =
Length of air duct + 40 mm
- Cut the air and flue ducts square and remove any burrs. Care should be taken not to scratch the white surface on the air duct.
- After cutting the tubes to size, insert the flue duct into the air duct and secure the air duct to the spacing bracket through the three pre-drilled holes.
- Lubricate the seals and install the flue extension.
- Ensure that the air duct clamps are centrally positioned over the 10 mm gap between the air duct sections.
- Drill two holes 3 mm Ø through each air duct (at either end of each clamp) at the most convenient holes in the air duct clamps and secure with screws provided. (Ensure that the drill does not penetrate the inner flue duct).
- Screw the clamp to the air ducts of the flue assembly and the boiler using the sheet metal screws supplied.

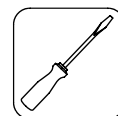

How to measure length of air and flue ducts

Measure the distance between centres of the two flue pipes to be connected. Using the table below identify and note the air duct length to be cut (Length of air duct).

Length of Air duct

- Cut the length of the air duct as follows:
Length of air duct as per table.

Length of Flue duct

- Cut the length of the flue duct as follows:
Length of flue duct = Length of air duct + 40 mm

Table 6.1: Length of surplus with 90° elbows

Distance between centres [in mm]	Length of air duct [in mm]	Distance between centres [in mm]	Length of air duct [in mm]	Distance between centres [in mm]	Length of air duct [in mm]
200, 205	0	505	295	730	520
210,	0	510	300	735	525
> 210 to < 310 mm	not possible	515	305	740	530
		520	310	745	535
		525	315	750	540
		530	320	755	545
		535	325	760	550
310	100	540	330	765	555
315	105	545	335	770	560
320	110	550	340	775	565
325	115	555	345	780	570
330	120	560	350	785	575
335	125	565	355	790	580
340	130	570	360	795	585
345	135	575	365	800	590
350	140	580	370	805	595
355	145	585	375	810	600
360	150	590	380	815	605
365	155	595	385	820	610
370	160	600	390	825	615
375	165	605	395	830	620
380	170	610	400	835	625
385	175	615	405	840	630
390	180	620	410	845	635
395	185	625	415	850	640
400	190	630	420	855	645
405	195	635	425	860	650
410	200	640	430	865	655
415	205	645	435	870	660
420	210	650	440	875	665
425	215	655	445	880	670
430	220	660	450	885	675
435	225	665	455	890	680
440	230	670	460	895	685
445	235	675	465	900	690
450	240	680	470	905	695
455	245	685	475	910	700
460	250	690	480	915	705
465	255	695	485	920	710
470	260	700	490	925	715
475	265	705	495	930	720
480	270	710	500	935	725
485	275	715	505	940	730
490	280	720	510		
495	285	725	515		
500	290				



FITTING AIR/FLUE DUCT EXTENSIONS BETWEEN TWO 45° ELBOWS

How to measure length of air and flue ducts

Measure the distance between centres of the two flue pipes to be connected. Using the table below identify and note the air duct length to be cut (Length of air duct).

Length of Air duct

- Cut the length of the air duct as follows:
Length of air duct as per table.

Length of Flue duct

- Cut the length of the flue duct as follows:
Length of flue duct = Length of air duct + 40 mm

Table 6.2: Length of surplus with 45° elbows

Distance between centres [in mm]	Length of air duct [in mm]	Height [in mm]	Distance between centres [in mm]	Length of air duct [in mm]	Height [in mm]	Distance between centres [in mm]	Length of air duct [in mm]	Height [in mm]		
80	0	194	315	311	429	515	594	629		
85	0	199	320	319	434	520	601	634		
90	0	204	325	326	439	525	608	639		
95	0	209	330	333	444	530	616	644		
			335	340	449	535	623	649		
> 95 -	not possible		340	347	454	540	630	654		
< 155 mm			345	354	459	545	637	659		
			350	361	464	550	644	664		
			355	368	469	555	651	669		
155			85	269	360	375	474	560	658	674
160			92	274	365	382	479	565	665	679
165			99	279	370	389	484	570	672	684
170	106	284	375	396	489	575	679	689		
175	113	289	380	403	494	580	686	694		
180	121	294	385	410	499	585	693	699		
185	128	299	390	418	504	590	700	704		
190	135	304	395	425	509	595	707	709		
195	142	309	400	432	514	600	715	714		
200	149	314	405	439	519	605	722	719		
205	156	319	410	446	524	610	729	724		
210	163	324	415	453	529	615	736	729		
215	170	329	420	460	534	620	743	734		
220	177	334	425	467	539	625	750	739		
225	184	339	430	474	544	630	757	744		
230	191	344	435	481	549	635	764	749		
235	198	349	440	488	554	640	771	754		
240	205	354	445	495	559	645	778	759		
245	212	359	450	502	564	650	785	764		
250	220	364	455	509	569					
255	227	369	460	517	574					
260	234	374	465	524	579					
265	241	379	470	531	584					
270	248	384	475	538	589					
275	255	389	480	545	594					
280	262	394	485	552	599					
285	269	399	490	559	604					
290	276	404	495	566	609					
295	283	409	500	573	614					
300	290	414	505	580	619					
305	297	419	510	587	624					
310	304	424								



How to fit sliding sleeves

NOTE:

For installations where there is insufficient movement to allow fitting of the flue into flue outlet, a sliding sleeve (Accy. No. 303 816) is available. When using the sliding sleeve both the air and flue ducts of the last extension must be shortened by a further 100 mm.

- Push the sliding sleeve over the cut end of the flue duct.
- Place the air duct clamp over the air duct.
- Pull back the sliding sleeve so that it engages into the socket of the boiler. Ensure that the sliding sleeve penetrates the socket such that there is at least 20 mm engagement at both ends of the sliding sleeve.
- Fit the air duct clamp over the air ducts of the extension/terminal and boiler outlet. Close the snap clamp.
- Drill two holes 3 mm diameter through the air duct clamp (the centre of the holes should be 6 mm from the edge of the clamp). Ensure that the drill does not penetrate the inner flue duct. Screw the air duct clamp to the air duct of the sleeve using the screws provided.
- Complete the installation of the flue as detailed in these instructions.

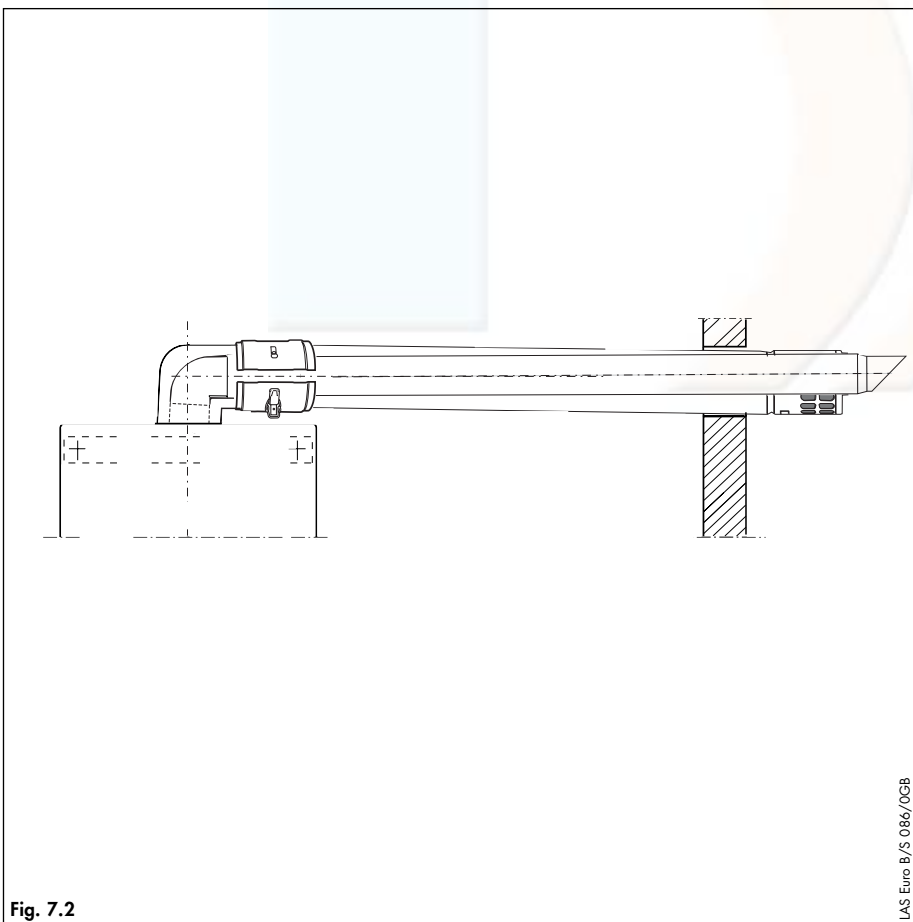
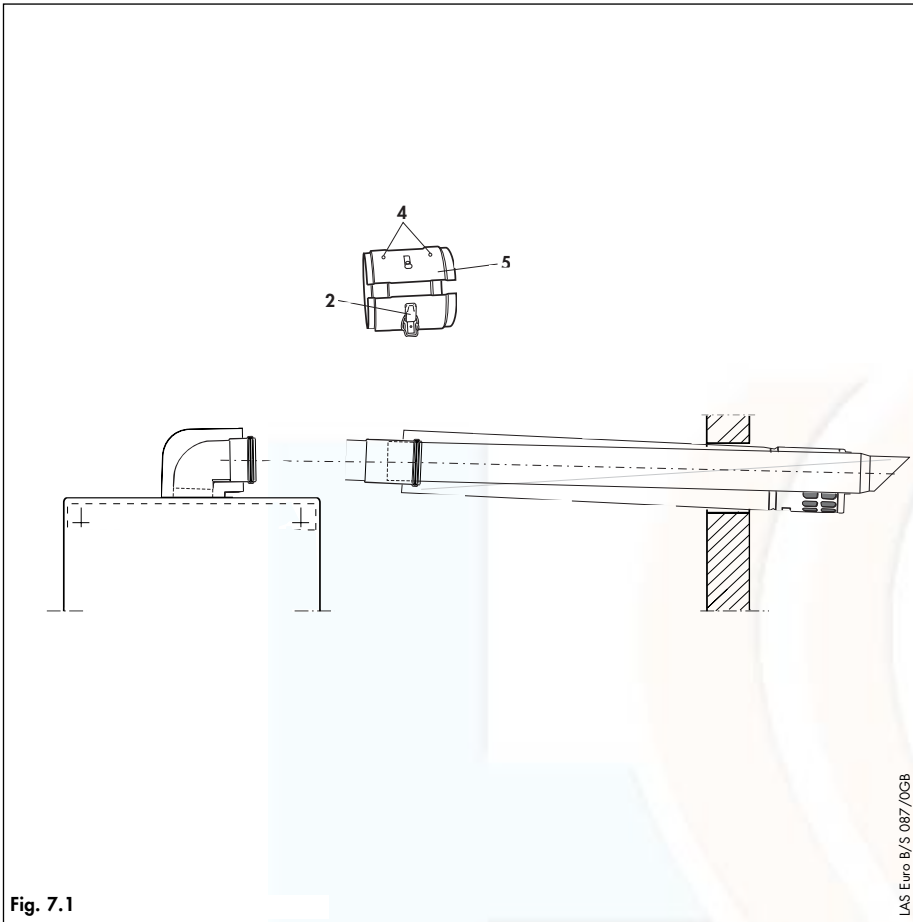



PLANNING THE AIR/FLUE DUCT LAYOUT

Termination accessories available



303 600 = Vertical roof duct(black)



303 609 = Horizontal wall/roof duct



303 814 = Appliance flue outlet adaptor

Optional connection accessories	Accy. Part No.	303 600	303 609
Air/flue duct extensions 500 mm - Ø 80/125	303 602	x	x
Air/flue duct extensions 1000 mm - Ø 80/125	303 603	x	x
Air/flue duct extensions 2000 mm - Ø 80/125	303 605	x	x
2 x 45° Bends Ø 80/125	303 611	x	x
87° Elbow Ø 80/125	303 610	x	x
Flue support clips (Pack of 5), Ø 125	303 616	x	x
Sliding sleeve Ø 80/125	303 617	x	x
Adjustable roof tile	9076	x	
Flat roof collar-piece	9056	x	

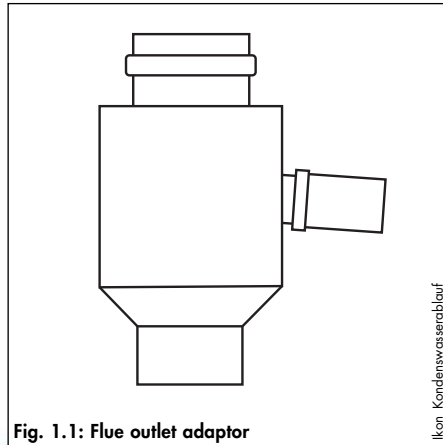

Fig. 1.1: Flue outlet adaptor

Appliance flue outlet adaptor
 Ø 60/100 - Ø 80/125

Accy. No.: 303 814
 (includes discharge tube and condensate trap)

ikon_Kondenswasserablauf

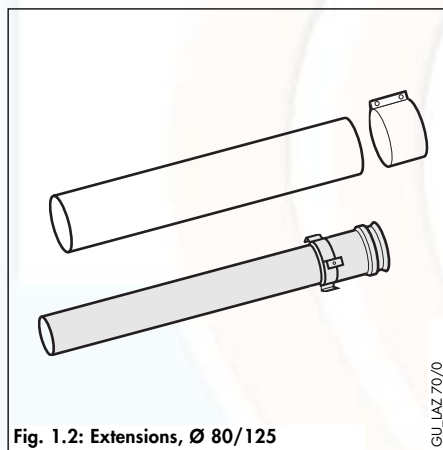

Fig. 1.2: Extensions, Ø 80/125

Air/flue duct extensions
 500 mm - Ø 80/125

Accy. No.: 303 602

Air/flue duct extensions
 1000 mm - Ø 80/125

Accy. No.: 303 603

Air/flue duct extensions
 2000 mm - Ø 80/125

Accy. No.: 303 604

GU_LAZ 70/0

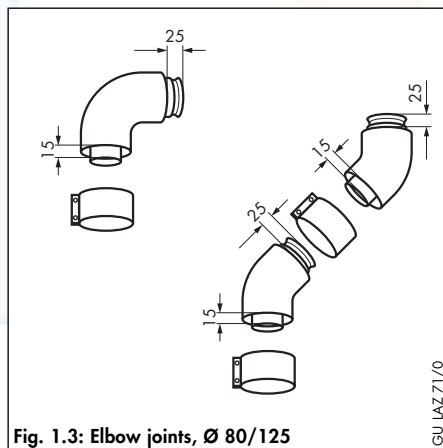

Fig. 1.3: Elbow joints, Ø 80/125

87° Elbow Ø 80/125

Accy. No.: 303 610

2 x 45° Bends, Ø 80/125

Accy. No.: 303 611

GU_LAZ 71/0

Use one clip per extension to support the air/flue duct.

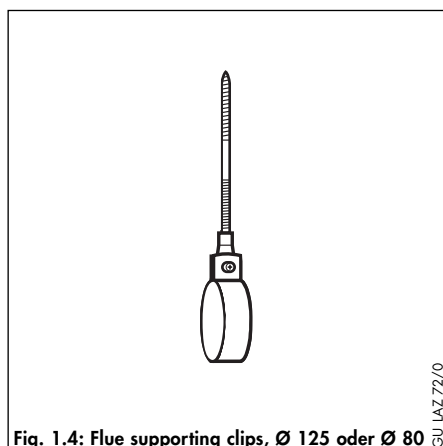

Fig. 1.4: Flue supporting clips, Ø 125 oder Ø 80

Flue support clips, Ø 125 (Pack of 5)

Accy. No.: 303 616

GU_LAZ 72/0



2 PLANNING THE AIR/FLUE DUCT LAYOUT

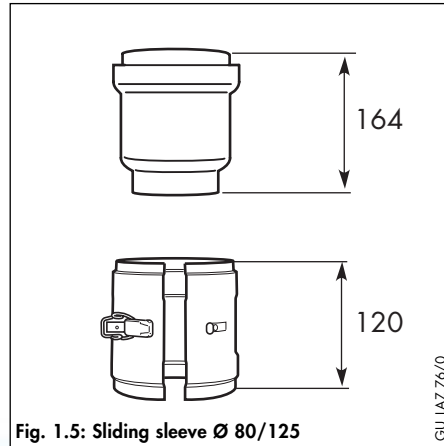

Sliding sleeve, Ø 80/125
Accy. No.: 303 617

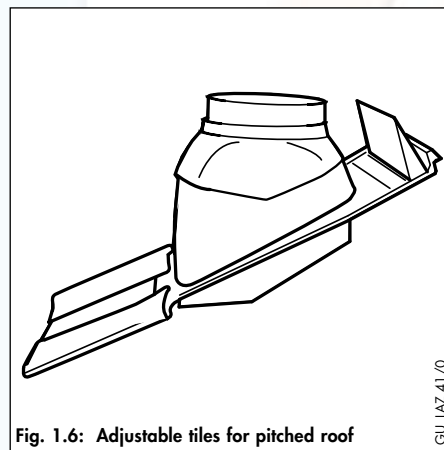

Adjustable roof tile
Accy. No.: 9076

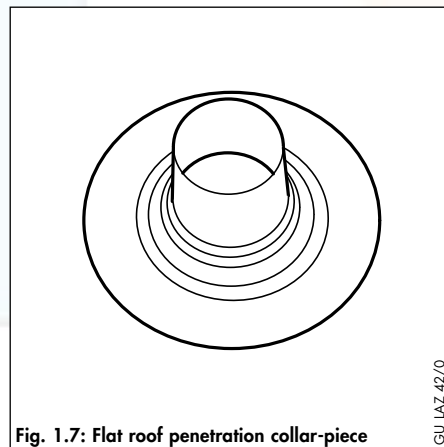

Flat roof penetration collar
Accy. No.: 9056



Maximum flue lengths Ø 80/125

	Accy. No.		thermoCOMPACT 615, 620, 624/2 E turboMAX plus 824/2 E turboMAX pro 24/2 E	thermoCOMPACT 628/2 E turboMAX plus 828/2 E turboMAX pro 28/2 E	turboMAX plus 837 E thermoCOMPACT 637 E, aquaPLUS
Horizontal flue system	303 609	Max. permitted flue length (L)	12.9 m Tube length is reduced by 2.5 m for each 87° elbow. Tube length is reduced by 1.0 m for each 45° elbow.	10.0 m	11.5 m
Vertical flue system	303 600	Max. permitted flue length (L)	15.4 m Tube length is reduced by 2.5 m for each 87° elbow. Tube length is reduced by 1.0 m for each 45° elbow.	12.5 m	14.0 m

PART 2 CONCENTRIC 80/125

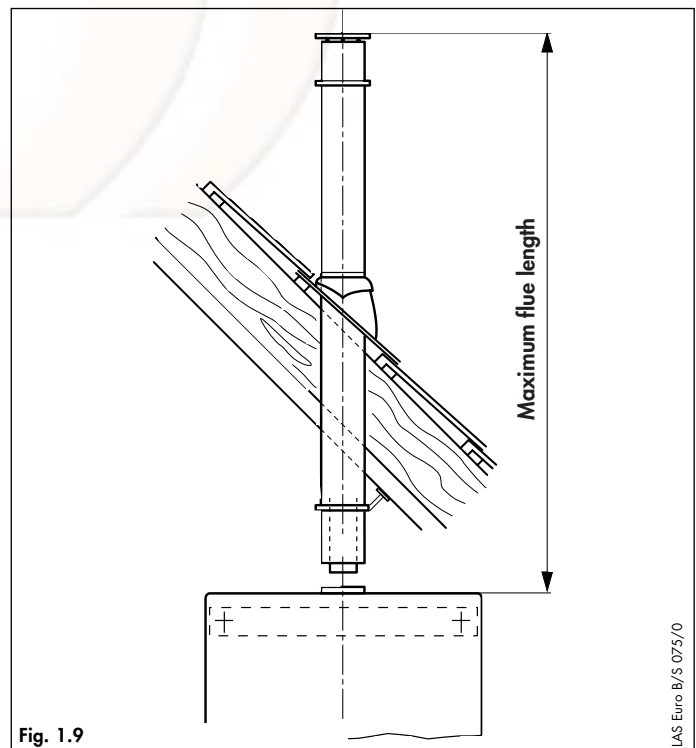
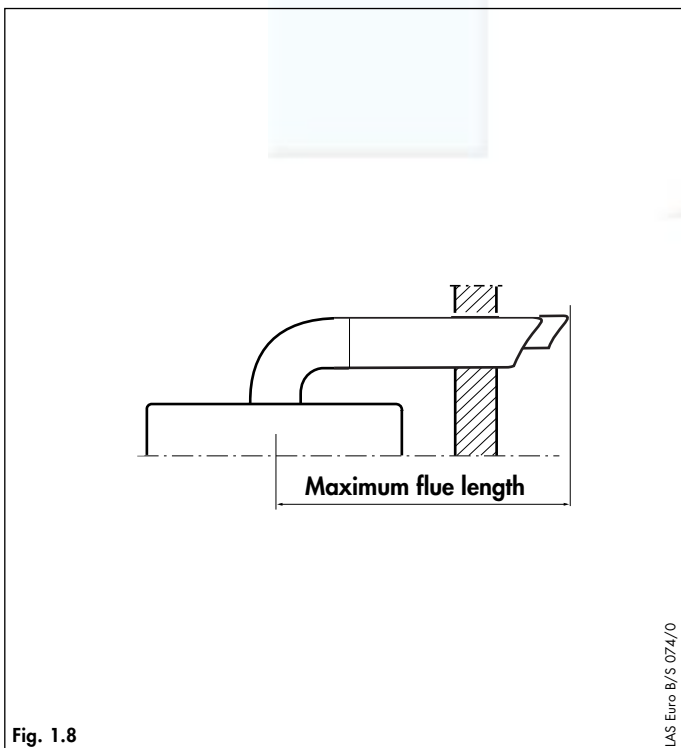



	Total equivalent flue length (incl. terminal any bends / elbows used)			
	thermoCOMPACT 615/2 E	thermoCOMPACT 620/2 E	thermoCOMPACT 624/2 E turboMAX plus 824/2 E turboMAX pro 24/2 E	thermoCOMPACT 628/2 E turboMAX plus 828/2 E turboMAX pro 28/2 E
Use restrictor A	—	< 15.4 m	—	—
Use restrictor C	—	—	< 9.2 m	—
Use restrictor D	—	—	9.2-12.0 m	< 6.0 m
No flue restrictor	—	—	> 12.0 m	> 6.0 m

Flue restrictor rings

The flue restrictor ring marked A, or C / D is packed with the boiler connection accessories. The restrictor ring should be fitted as shown in the diagram according to the equivalent flue length in the table.

The total equivalent flue length is the total length of the flue (including the terminal assembly for vertical flues), plus the resistance of any bends or elbows used.

- equivalent length of 87° elbow is 2.5 m
- equivalent length of 45° elbow is 1 m

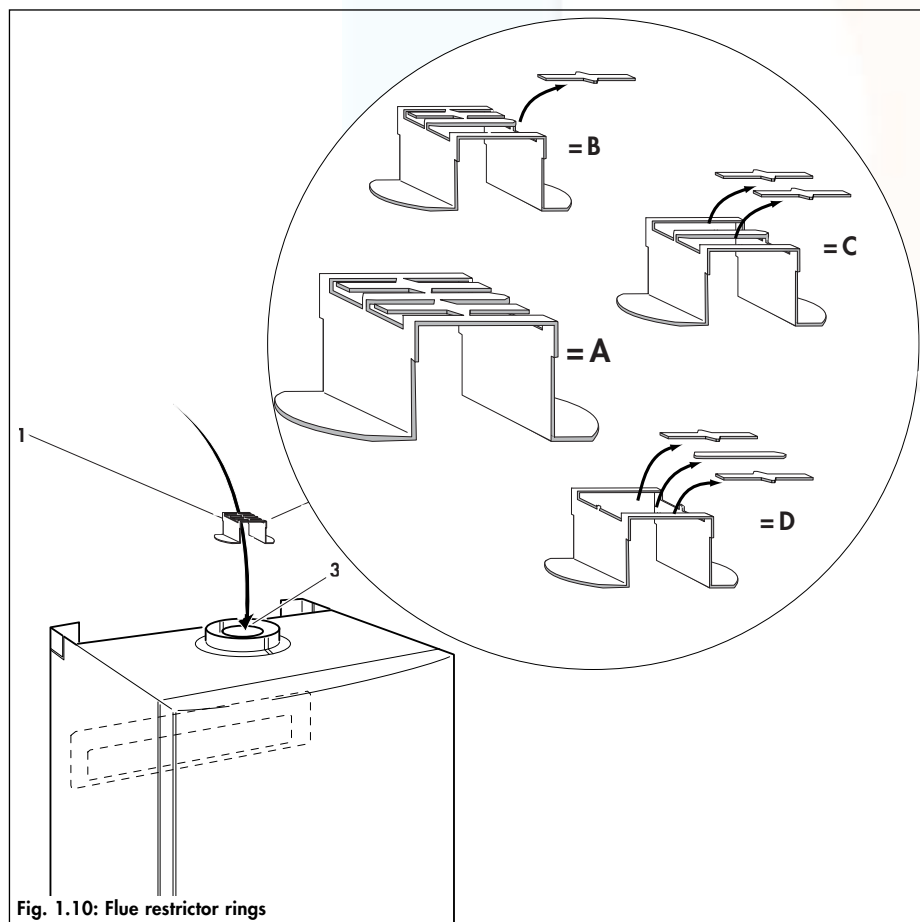

Fig. 1.10: Flue restrictor rings

- Push the restrictor (1) into the flue connection of the appliance (3).
- Connect the flue outlet adaptor (2) into the flue connection of the appliance (3).

Note: The flue outlet on the top of the boiler has a diameter of 100 mm. An adaptor (Accy. No. 303 814) is required to connect from the boiler outlet to the 125 mm diameter flue system. This adaptor incorporates a condensate discharge connection which allows any condensate or water to drain away. It is important that the condensate discharge connector is connected correctly.

Note: thermoCOMPACT 615 boilers do not require a separate restrictor ring and are supplied without the restrictor. The required restriction is designed into the flue connection piece for these boilers.



	Total equivalent flue length (incl. terminal any bends / elbows used)			
		thermoCOMPACT 637 E	turboMAX plus 837 E	aquaPLUS
Use restrictor F0	–	< 5.5 m	< 5.5 m	< 5.5 m
Use restrictor F1	–	5.5 - 8.5 m	5.5 - 8.5 m	5.5 - 8.5 m
Use restrictor F2	–	8.5 - 10.5 m	8.5 - 10.5 m	8.5 - 10.5 m
No flue restrictor	–	> 10.5 m	> 10.5 m	> 10.5 m

Flue restrictor rings

Two flue restrictor rings marked F0 to F2 are packed with the boiler connection accessories. The restrictor rings should be fitted as shown in the diagram according to the equivalent flue length in the table.

The total equivalent flue length is the total length of the flue (including the terminal assembly for vertical flues), plus the resistance of any bends or elbows used.

- equivalent length of 87° elbow is 2.5 m
- equivalent length of 45° elbow is 1 m

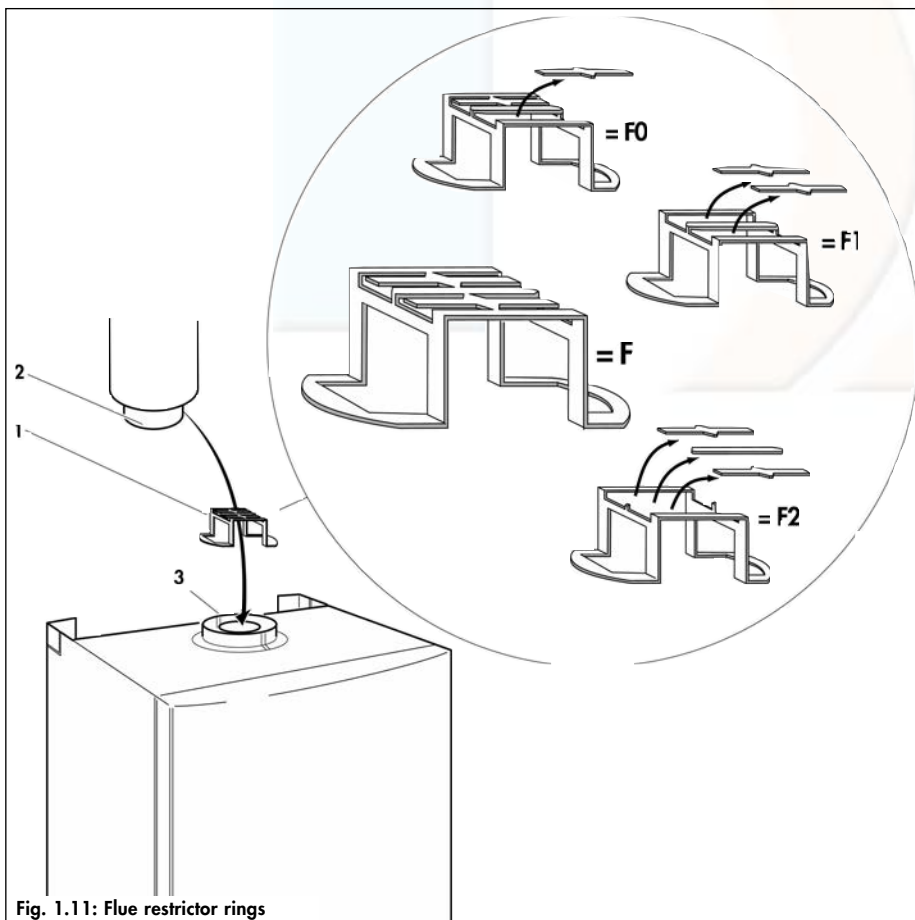

Fig. 1.11: Flue restrictor rings

- Push the restrictor (1) into the flue connection of the appliance (3).
- Connect the flue outlet adaptor (2) into the flue connection of the appliance (3).

Note: The flue outlet on the top of the boiler has a diameter of 100 mm. An adaptor (Accy. No. 303 814) is required to connect from the boiler outlet to the 125 mm diameter flue system. This adaptor incorporates a condensate discharge connection which allows any condensate or water to drain away. It is important that the condensate discharge connector is connected correctly.



2 FITTING THE APPLIANCE FLUE OUTLET ADAPTER TO THE BOILER

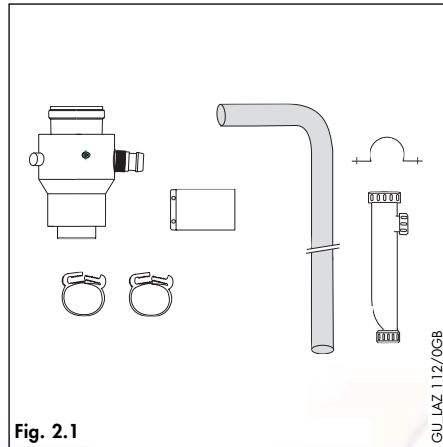

Fig. 2.1

Appliance flue outlet adaptor

Accy. No.: 303 814

Ø 60/100 to Ø 80/125

Contents of the accessory:

- Adaptor including condensate discharge connection
- 48 mm Air duct clamp
- Condensate trap
- Condensate discharge tube
- 2 Plastic ratchet clips
- Support clip

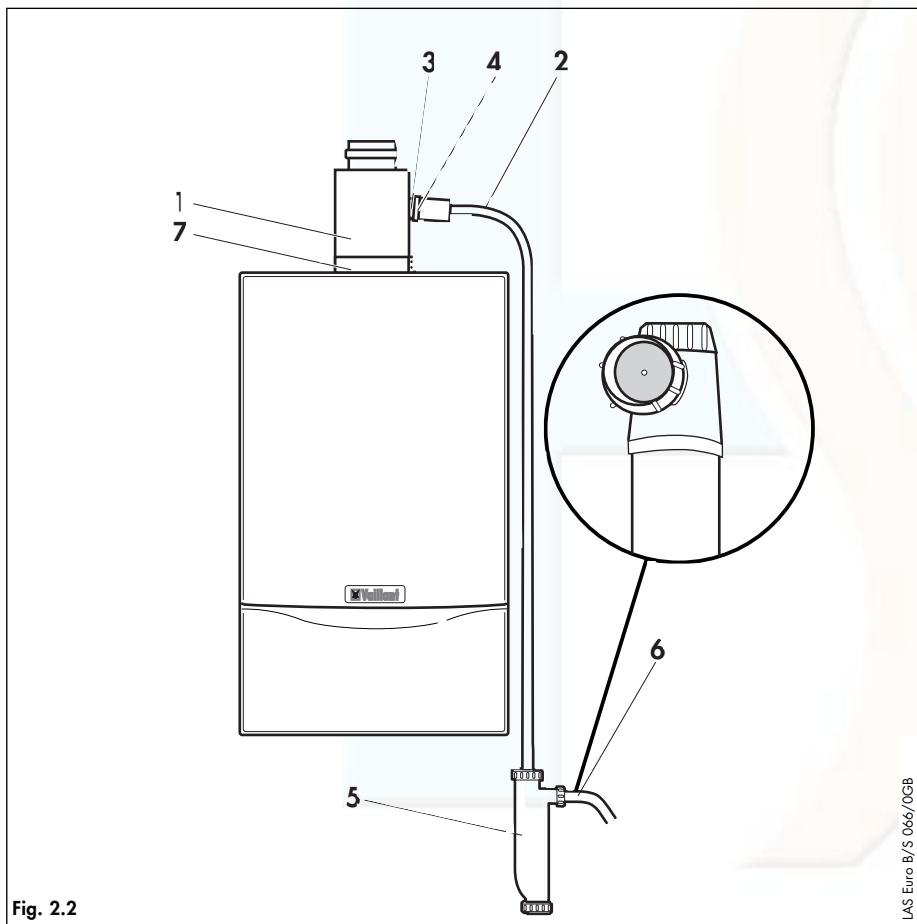

Fig. 2.2

- Before installing the adaptor onto the boiler outlet select and fit the correct restrictor (page 33). For turboMAX boilers fit the restrictor into the bottom of the adaptor (page 34). For thermoCOMPACT boilers refer to the installation instructions supplied with the boiler for details on fitting the restrictor.
- Fit the adaptor to the boiler by inserting the spigot of the adaptor (1) into the flue socket on the boiler and secure using the air duct clamp provided (7).
- Drill two holes 3 mm Ø through the air duct clamp and secure the air duct clamp to the boiler using the screws provided.

Note: Because of the high efficiency of turboMAX, thermoCOMPACT and aquaPLUS boilers it is likely that condensate will form in the flue system when a long flue run is used. A condensate discharge connection is provided on the adaptor to remove any condensate that forms in the flue.



Connecting the condensate discharge system

- A condensate discharge connection (3) is provided on the adaptor to remove any condensate or other water which may form in the flue system.
- Connect the condensate discharge tube (2) to the condensate discharge connection point (4) on the adaptor and secure with the plastic ratchet clip provided.

Important: Ensure that there are no kinks in the condensate discharge pipe.

- Position the trap (5) below the appliance and secure to the wall using the bracket and screws provided. Connect the condensate discharge tube to the top connection of the trap ensuring that the condensate discharge tube engages into the trap by a minimum of 90 mm.
- Connect the outlet of the condensate trap (6) to a suitable drain point.

Important: Before operating the boiler the condensate trap must be filled with water.

- Use only the condensation hose and condensate trap supplied with the accessory.

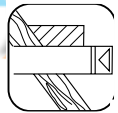

INSTALLATION OF THE HORIZONTAL AIR/FLUE DUCT Ø 80/125 WITH EXTENSIONS

IMPORTANT:

The flue hole should be cut with a slight rise to outside of $3^{\circ} \pm 1^{\circ}$ (equivalent to $50\text{mm} \pm 20\text{mm}$ rise per metre length)

Preparation

- Determine the installation site for the boiler with reference to the installation and servicing instructions supplied with the boiler.
- Ensure that all installation and service clearances are available and that the boiler flue can be installed as detailed in these instructions.
- Fix the paper template, supplied with the boiler, to the wall ensuring that the centreline of the template is vertical using a plumbline or spirit level.

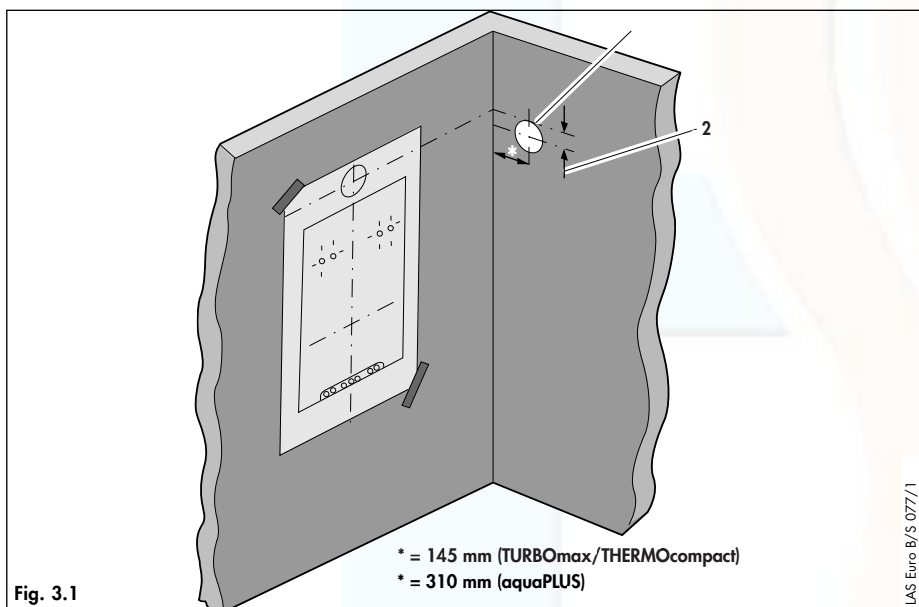

Fig. 3.1

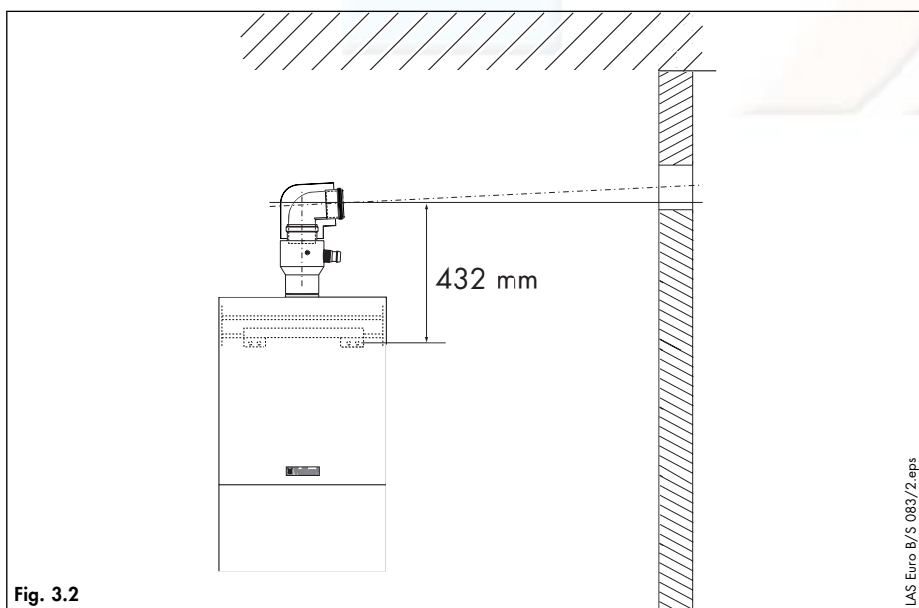

Fig. 3.2

Side flue installations

- For installations where the air/flue duct is to be installed to the side, the position of the flue exit hole can be determined as follows:
- Identify the correct measurement as shown in fig. 3.2, carefully measure the distance from the bottom centre of the boiler hanging bracket (centreline of the two lower hanging bracket fixing holes). This gives the position of the centreline of the 125 mm flue elbow and adaptor when installed.
- The position of the flue exit hole can be determined by carefully levelling across the wall from this mark.
- The position of the flue exit hole should allow the flue to be installed with an upwards slope towards the terminal of approximately 3° , equivalent to 50 mm rise per 1 metre of flue length. Calculate the required rise according to the flue length and mark the position of the flue exit hole.

Note: Due to the long lengths of flue possible and the slope required, it may be necessary to adjust the location of the boiler installation template. Please check that both the boiler installation site and flue termination are in accordance with these instructions prior to drilling any holes for the boiler hanging bracket.

- Once the position of the flue exit hole has been determined, the hole should be cut through the wall using a core drill of 127 mm diameter. The flue exit hole should be cut with a rise towards outside of 3° .
- Measure the distance from the outside face of the wall to the centre of the fan outlet on the boiler (fig. 3.3). **This is dimension A.**
- For installations where the measured distance dimension A (fig. 3.3) is greater than 960 mm, an air/flue extension accessory will be required. The number of air/flue duct extensions which can be used depends on the boiler.

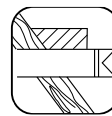

INSTALLATION OF THE HORIZONTAL AIR/FLUE DUCT Ø 80/125 WITH EXTENSIONS

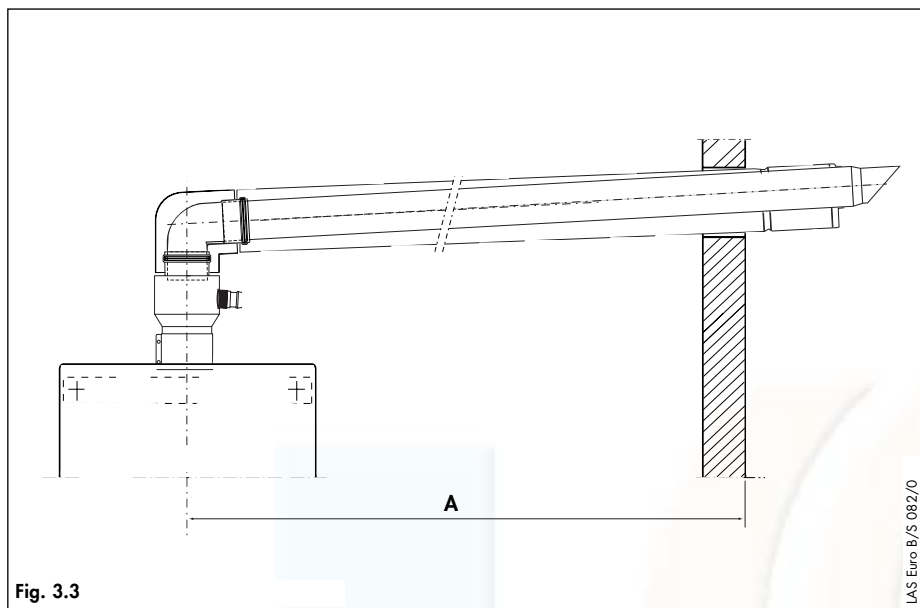

Fig. 3.3

LAS Euro B/S 082/0

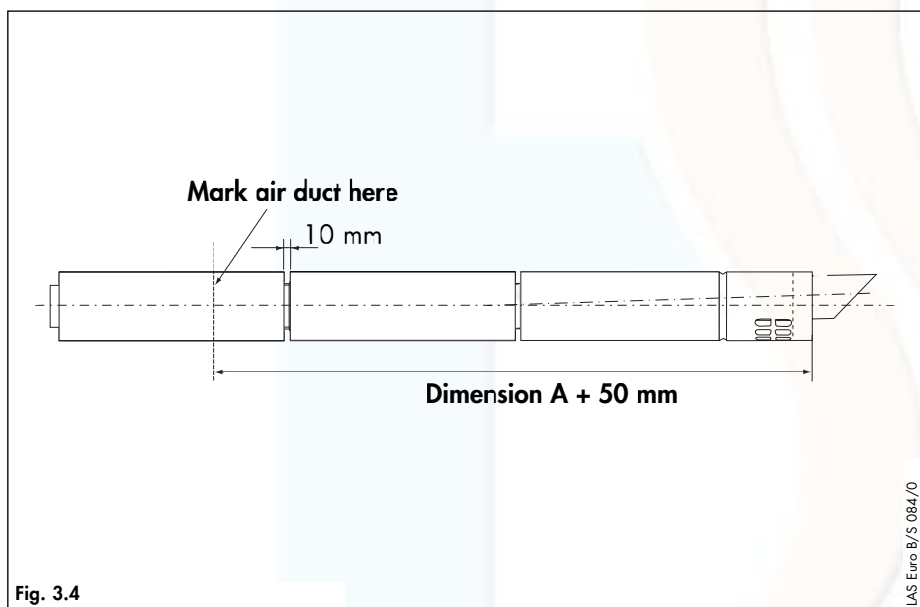

Fig. 3.4

LAS Euro B/S 084/0

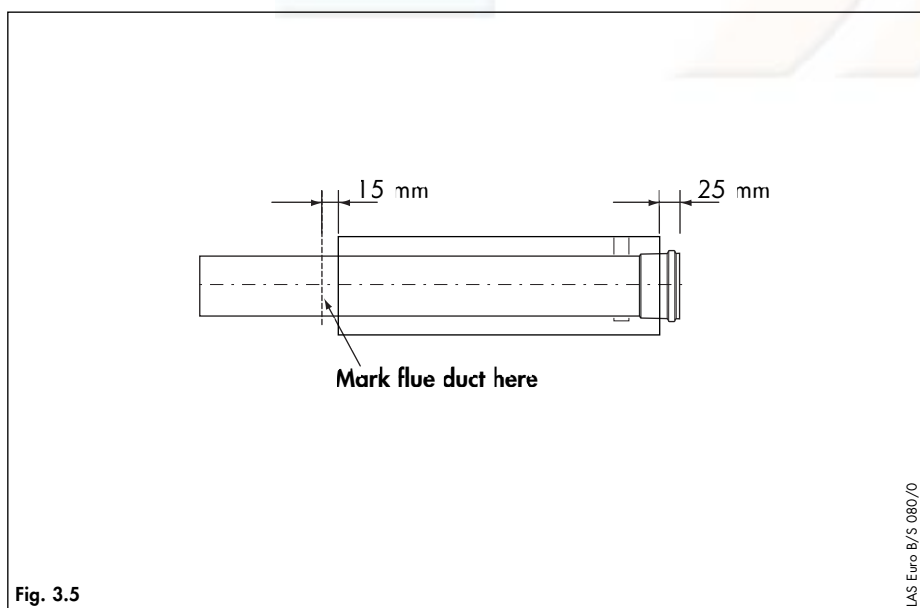

Fig. 3.5

LAS Euro B/S 080/0

- Taking each extension to be used, fit the flue duct into the air duct and secure using the 3 screws provided.
- For ease of measuring and marking the air/flue duct extensions, assemble them loosely together with the air/flue duct and terminal assembly as shown (fig. 3.4).

Note: The joints between the flue duct sections are of a push-fit type, with the flue duct spigot inserted into a socket containing a sealing ring. For ease of installation lubricate the seal using soap solution prior to assembling.

- Assemble the flue such that there is a gap of about 10 mm between each air duct, which will ensure the correct flue duct penetration into the flue sockets of 30 mm. All flue sockets should point towards the flue terminal.
- Measure from the flue terminal and mark the air duct to a length of:

Dimension A + 50 mm

- Take the extension(s) to be shortened and remove the 3 screws. Separate the ducts.
- Cut the air duct square and remove any burrs.
- Refit the flue duct into the air duct and secure using the 3 screws.
- Cut the flue duct as detailed in fig. 3.5.

Note: For assembly reasons do not shorten any air duct to a length of less than 100 mm. If necessary shorten two adjacent extensions to achieve the overall required length.

- When cutting the air and flue ducts it is important to remove any burrs with a file, this ensures easy fitting of the ducts and prevents any rough edges from damaging the flue seals.
- Care should be taken not to scratch the white surface of the air duct.
- If the installation requires the use of air/flue duct extensions, additional bends or elbows refer to the sections on pages 45 - 47.
- At this stage it is necessary to prepare and fit the boiler onto the hanging bracket – refer to the boiler installation instructions.
- Fit the appliance flue outlet adaptor to the boiler.



INSTALLATION OF THE HORIZONTAL AIR/FLUE DUCT AND TERMINAL ACCESSORY (80/125 Ø)

IMPORTANT:

The flue hole should be cut with a slight rise to outside of $3^{\circ} \pm 1^{\circ}$ (equivalent to $50\text{mm} \pm 20\text{mm}$ rise per metre length)

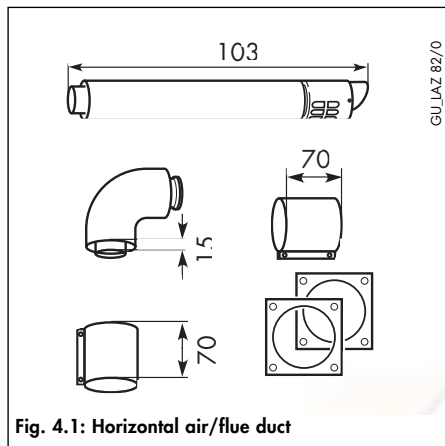

Fig. 4.1: Horizontal air/flue duct

Horizontal air/flue duct and terminal accessory

Accy. No.: 303 609

The set contains:

- Horizontal air/flue duct and terminal assembly
- 87° elbow
- 2 x 70 mm air duct clamps
- 2 trim rings $\text{Ø} 125$

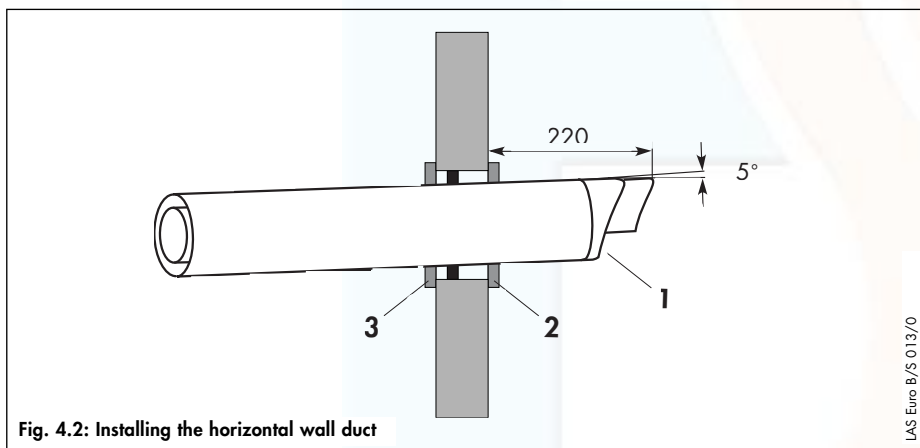
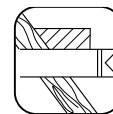

Fig. 4.2: Installing the horizontal wall duct

Preparation

- Push the assembled air/flue duct and terminal assembly through the flue exit hole until it protrudes 220 mm out from the outside wall.
- Ensure that the terminal is correctly positioned with the air inlet grille at the bottom.
- Slide one of the two trim rings over the air duct until it is flush with the internal wall face.



INSTALLATION OF THE HORIZONTAL AIR/FLUE DUCT AND TERMINAL ACCESSORY (80/125)

Fitting extensions

- Install the flue extensions by working from the installed air/flue and terminal accessory back towards the boiler.
- The joints between the flue duct sections are made by pushing the flue duct spigot into the socket of the flue duct extension by 30 mm. This is achieved when the gap between the air duct sections is 10 mm.
- All sockets should point towards the flue terminal.
- The joints between the air duct sections should be clamped using the air duct clamps.
- Ensure that the air duct clamps are positioned centrally.
- Drill two 3 mm diameter holes through the air duct (ensure that the drill does not pierce the inner flue duct). Fix the duct using the screws provided.
- Ensure that the flue assembly is adequately supported along its entire length.
- Cut any air/flue ducts to the required length as detailed on page 45.

Connect the flue assembly to the adaptor

- Slide the 125 mm dia x 88 mm long air duct clamp over the air duct.
- Fit the 87° elbow to the last flue extension.
- Line up the elbow with the adaptor and insert the spigot of the elbow in to the adaptor.
- Locate the air duct clamps ensuring they are positioned centrally.
- Drill two holes 3mm Ø through the air duct through both the air duct clamps at the most convenient holes on the air duct clamps. (Ensure that the drill does not penetrate the inner flue duct). Screw the clamps to the air ducts of the flue assembly, the elbow and boiler using the sheet metal screws supplied.
- Slide the internal trim ring back to the wall, securing in position with a small amount of sealant if required.

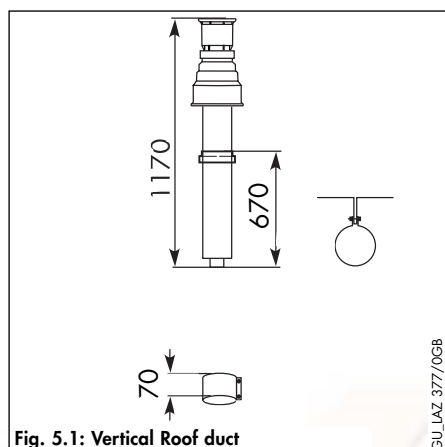

Fig. 5.1: Vertical Roof duct

Vertical air/flue duct and terminal accessory

Accy. No.: 303 600

Contents of the accessory:

- Vertical air/flue duct and terminal assembly
- 70 mm Air duct clamp
- Fixing bracket

Preparation

- Determine the installation site for the boiler with reference to the installation and servicing instructions supplied with the boiler.
- Ensure that all installation and service clearances are available and that the boiler flue can be installed as detailed in these instructions.
- Fix the paper template, supplied with the boiler, to the wall ensuring that the centreline of the template is vertical using a plumbline or spirit level.

Please note: The vertical air/flue duct and terminal accessory (Accy. 303 600) may be shortened. The outer 'white' duct should be shortened first, then the inner flue duct cut so that it protrudes 15 mm out of the air duct. In case of installation directly to the boiler without elbows or bends, it is essential that the roof tile/collar is vertically aligned with the air/flue duct of the boiler.

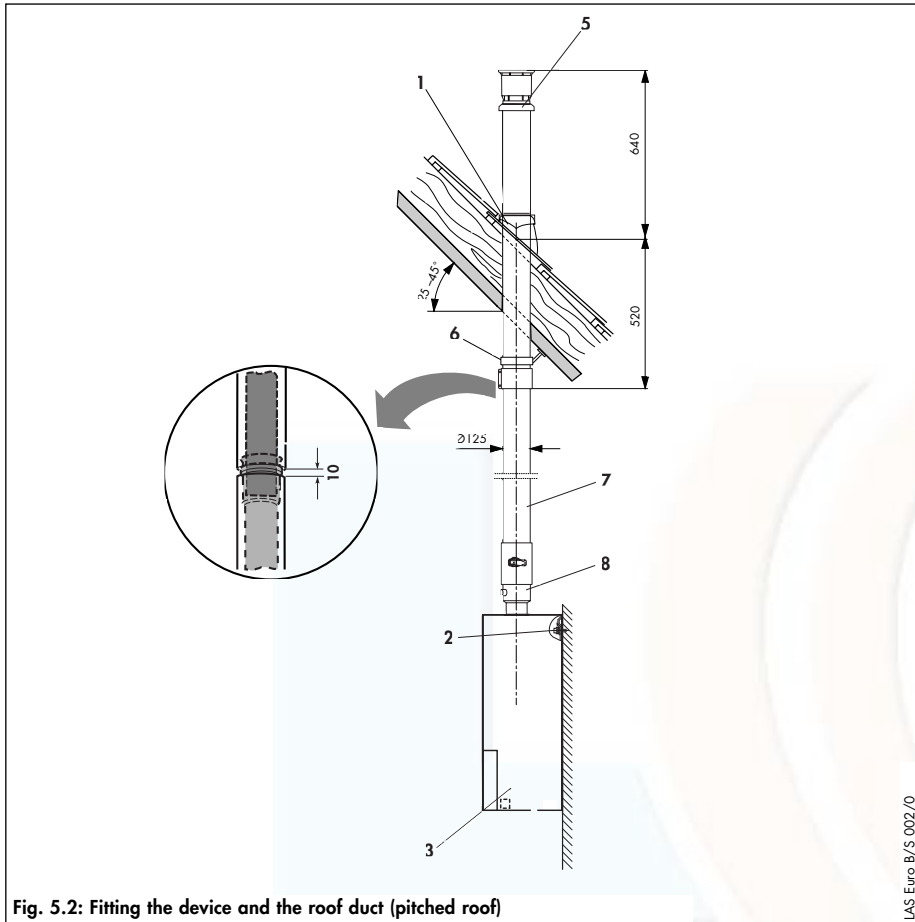
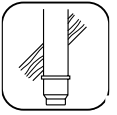

Fig. 5.2: Fitting the device and the roof duct (pitched roof)

Pitched roof

- Determine the point of termination of the vertical air/flue duct and terminal assembly.
- Install the adjustable pitched roof tile (1) in position.
- Fit the adjustable hood over the roof tile according to the roof pitch. The adjustable hood is suitable for roof pitches from 25° to 35°, or 35° to 45° by reversing.

Flat roof

- Determine the point of termination of the vertical air/flue duct and terminal assembly.
- Make a hole in the roof of 135 mm diameter. Secure the flat roof collar (1) to the roof covering above the hole in accordance with the codes of practice for flat roofs CP 144) to ensure a watertight seal.

Pitched and flat roof installations

- From above insert the air/flue duct and terminal assembly (5) into the adjustable roof tile (pitched roof) or roof penetration collar (flat roof) until it is fully seated.
- Adjust the vertical alignment of the air/flue duct and terminal assembly and secure the air duct with the fixing bracket provided. (6).
- At this stage it is necessary to prepare and fit the boiler onto the hanging bracket – refer to the boiler installation instructions.
- For installations where an air/flue extension accessory will be required. The number of air/flue duct extensions which can be used depends on the boiler.

Note: The joints between the flue duct sections are of a push-fit type, with the flue duct spigot inserted into a socket containing a sealing ring. For ease of installation lubricate the seal using soap solution prior to assembling.

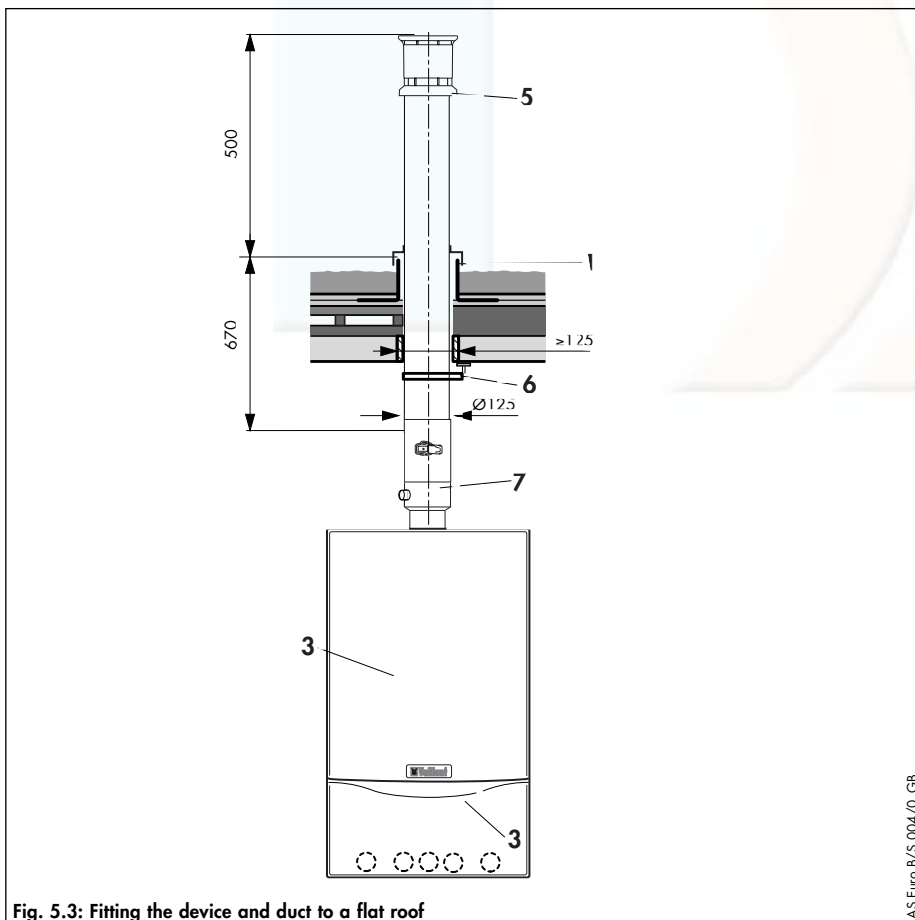

Fig. 5.3: Fitting the device and duct to a flat roof



2 INSTALLATION OF THE VERTICAL ROOF DUCT

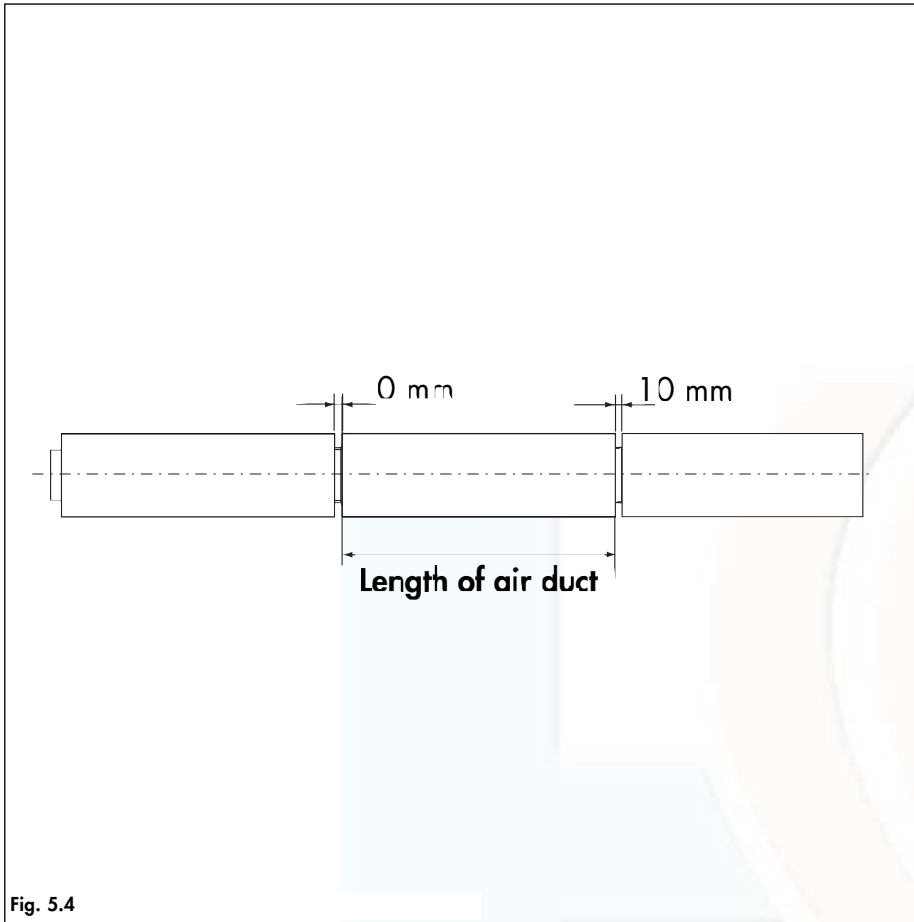

Fig. 5.4

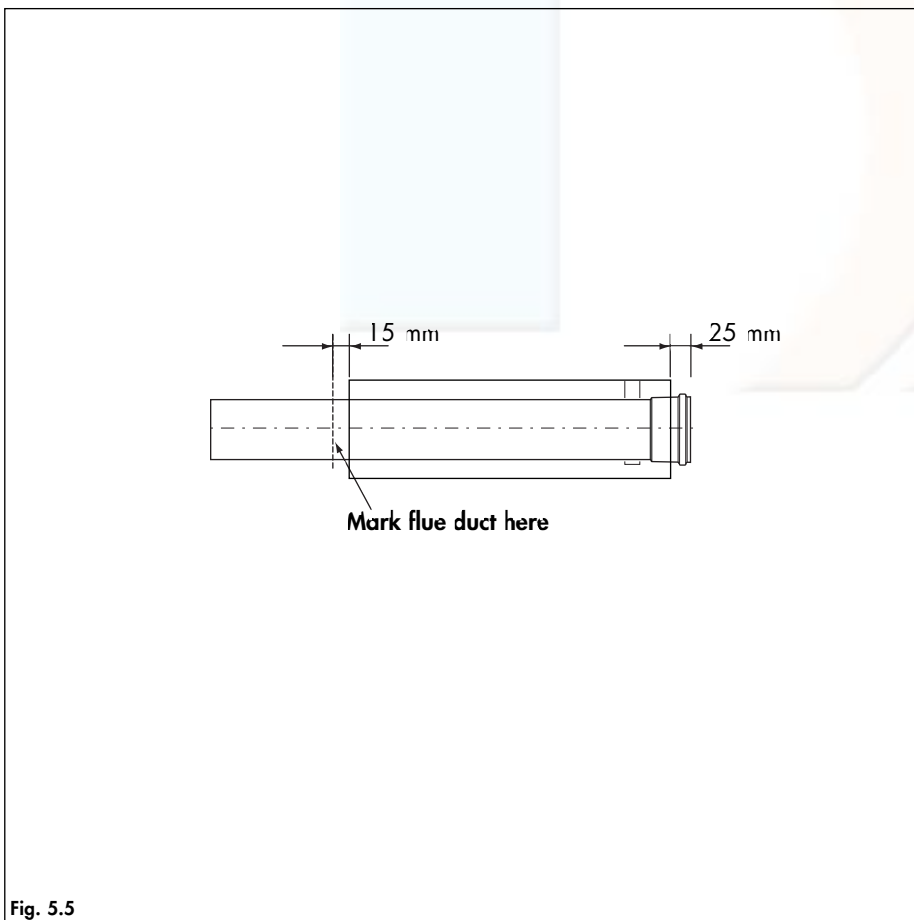
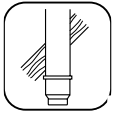

Fig. 5.5

- Assemble the flue such that there is a gap of about 10 mm between each air duct, which will ensure the correct flue duct penetration into the flue sockets of 30 mm. All flue sockets should point towards the flue terminal.
- Measure the air duct (from the end with the 3 fixing holes) and mark the air duct to this length.
- Take the extension(s) to be shortened and remove the 3 screws. Separate the ducts.

Note: For assembly reasons do not shorten any air duct to a length of less than 100 mm. If necessary shorten two adjacent extensions to achieve the overall required length.

- Cut the air duct square.
- Refit the flue duct into the air duct and secure using the 3 screws.
- Cut the flue duct as detailed in figure 5.5.
- When cutting the air and flue ducts it is important to remove any burrs with a file, this ensures easy fitting of the ducts and prevents any rough edges from damaging the flue seals.
- Care should be taken not to scratch the white surface of the air duct.
- If the installation requires the use of air/flue duct extensions, additional bends or elbows refer to the sections on pages 45 - 47.
- Install the flue extensions by working from the installed air/flue and terminal accessory back towards the boiler.
- The joints between the flue duct sections are made by pushing the flue duct spigot into the socket of the flue duct extension by 30 mm. This is achieved when the gap between the air duct sections is 10 mm.
- All sockets should point towards the flue terminal.
- The joints between the air duct sections should be clamped using the air duct clamps.
- Ensure that the air duct clamps are positioned centrally.



- Drill two 3 mm diameter holes through the air duct (ensure that the drill does not pierce the inner flue duct). Fix the duct using the screws provided.
- Ensure that the flue assembly is adequately supported along its entire length.
- Fit the appliance flue outlet adaptor to the boiler.
- Ensure that any air duct clamps used are positioned centrally and fixed to the air duct using the self tapping screws supplied.

Connect the flue assembly to the adaptor

- Slide the 125 mm dia x 88 mm long air duct clamp over the air duct.
- Line up the air/flue duct with the adaptor and insert the spigot of the air/flue duct in to the adaptor.
- Locate the air duct clamps ensuring they are positioned centrally.
- Drill two holes 3 mm Ø through the air duct through both the air duct clamps at the most convenient holes on the air duct clamps. (Ensure that the drill does not penetrate the inner flue duct). Screw the clamps to the air ducts of the flue assembly, the elbow and boiler using the sheet metal screws supplied.



FITTING AIR/FLUE DUCT EXTENSIONS

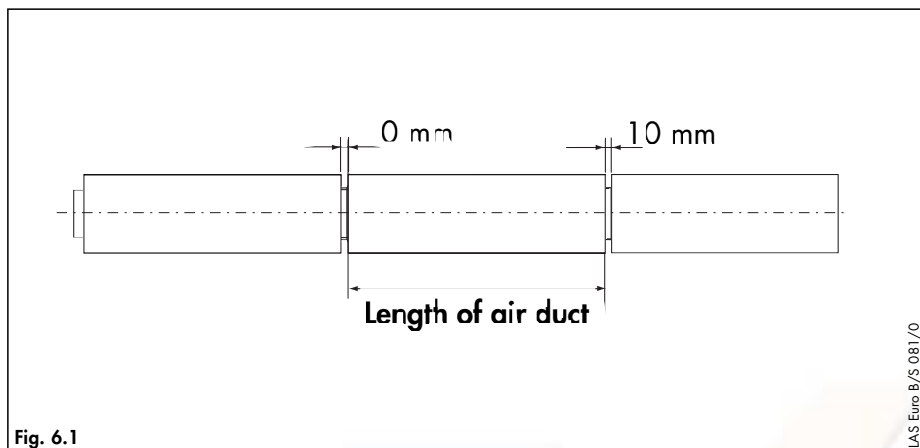

Cutting extensions

- Measure and note the length of the air duct extension required for the installation (a).

Note: Extensions should be assembled so there is a gap of 10 mm between each air duct.

Use this measurement to calculate the length to cut the air and flue ducts:

Length of Air duct

- Cut the length of the air duct as follows:
Length of air duct as shown in fig. 6.1.

Length of Flue duct

- Cut the length of the flue duct as follows:
Length of flue duct =
length of air duct + 40 mm
- Cut the air and flue ducts square and remove any burrs. Care should be taken not to scratch the white surface on the air duct.
- After cutting the tubes to size, insert the flue duct into the air duct and secure the air duct to the spacing bracket through the three pre-drilled holes.
- Install the flue extension.
- Ensure that the air duct clamps are centrally positioned over the 10 mm gap between the air duct sections.
- Drill two holes 3 mm Ø through each air duct (at either end of the extension) at the most convenient holes in the air duct clamps and secure with screws provided.
- **Note: The air duct clamp must not be screwed to the bottom the air/flue duct and terminal assembly, this will allow the clamp to absorb any slight movement in the roof structure.**

FITTING AIR/DUCT EXTENSIONS BETWEEN TWO 90° ELBOWS



How to measure length of air and flue ducts

Measure the distance between centres of the two flue pipes to be connected. Using the table below identify and note the air duct length to be cut (Length of air duct).

Length of Air duct

- Cut the length of the air duct as follows:
Length of air duct as per table.

Length of Flue duct

- Cut the length of the flue duct as follows:
Length of flue duct = Length of air duct + 40 mm

Table 6.1: Length of surplus with 87° elbows

Distance between centres [in mm]	Length of air duct [in mm]	Distance between centres [in mm]	Length of air duct [in mm]	Distance between centres [in mm]	Length of air duct [in mm]
200, 205	0	505	295	730	520
210,	0	510	300	735	525
> 210 to	not possible	515	305	740	530
< 310 mm		520	310	745	535
		525	315	750	540
		530	320	755	545
310	100	535	325	760	550
315	105	540	330	765	555
320	110	545	335	770	560
325	115	550	340	775	565
330	120	555	345	780	570
335	125	560	350	785	575
340	130	565	355	790	580
345	135	570	360	795	585
350	140	575	365	800	590
355	145	580	370	805	595
360	150	585	375	810	600
365	155	590	380	815	605
370	160	595	385	820	610
375	165	600	390	825	615
380	170	605	395	830	620
385	175	610	400	835	625
390	180	615	405	840	630
395	185	620	410	845	635
400	190	625	415	850	640
405	195	630	420	855	645
410	200	635	425	860	650
415	205	640	430	865	655
420	210	645	435	870	660
425	215	650	440	875	665
430	220	655	445	880	670
435	225	660	450	885	675
440	230	665	455	890	680
445	235	670	460	895	685
450	240	675	465	900	690
455	245	680	470	905	695
460	250	685	475	910	700
465	255	690	480	915	705
470	260	695	485	920	710
475	265	700	490	925	715
480	270	705	495	930	720
485	275	710	500	935	725
490	280	715	505	940	730
495	285	720	510		
500	290	725	515		



FITTING AIR/FLUE DUCT EXTENSIONS BETWEEN TWO 45° ELBOWS

How to measure length of air and flue ducts

Measure the distance between centres of the two flue pipes to be connected. Using the table below identify and note the air duct length to be cut (Length of air duct).

Length of Air duct

- Cut the length of the air duct as follows:
Length of air duct as per table.

Length of Flue duct

- Cut the length of the flue duct as follows:
Length of flue duct = Length of air duct + 40 mm

Table 6.2: Length of surplus with 45° elbow

Distance between centres [in mm]	Length of air duct [in mm]	Height [in mm]	Distance between centres [in mm]	Length of air duct [in mm]	Height [in mm]	Distance between centres [in mm]	Length of air duct [in mm]	Height [in mm]
90	0	210	335	334	455	535	617	655
95	0	215	340	341	460	540	624	660
100	0	220	345	348	465	545	631	665
> 100 to < 170 mm	not possible		350	355	470	550	638	670
			355	362	475	555	645	675
			360	369	480	560	652	680
			365	376	485	565	659	685
			370	383	490	570	666	690
			375	390	495	575	673	695
			380	397	500	580	680	700
170	100	290	385	405	505	585	687	705
175	108	295	390	412	510	590	695	710
180	115	300	395	419	515	595	702	715
185	122	305	400	426	520	600	709	720
190	129	310	405	433	525	605	716	725
195	136	315	410	440	530	610	723	730
200	143	320	415	447	535	615	730	735
205	150	325	420	454	540	620	737	740
210	157	330	425	461	545	625	744	745
215	164	335	430	468	550	630	751	750
220	171	340	435	475	555	635	758	755
225	178	345	440	482	560	640	765	760
230	185	350	445	489	565	645	772	765
235	192	355	450	496	570	650	779	770
240	199	360	455	504	575	655	786	775
245	207	365	460	511	580	660	794	780
250	214	370	465	518	585	665	801	785
255	221	375	470	525	590	670	808	790
260	228	380	475	532	595	675	815	795
265	235	385	480	539	600	680	822	800
270	242	390	485	546	605	685	829	805
275	249	395	490	553	610	690	836	810
280	256	400	495	560	615	695	843	815
285	263	405	500	567	620	700	850	820
290	270	410	505	574	625	705	857	825
295	277	415	510	581	630	710	864	830
300	284	420	515	588	635	715	871	835
305	291	425	520	596	640	720	878	840
310	298	430	525	603	645			
315	306	435	530	610	650			
320	313	440						
325	320	445						
330	327	450						

INSTALLING THE AIR/FLUE DUCT SLIDING SLEEVE

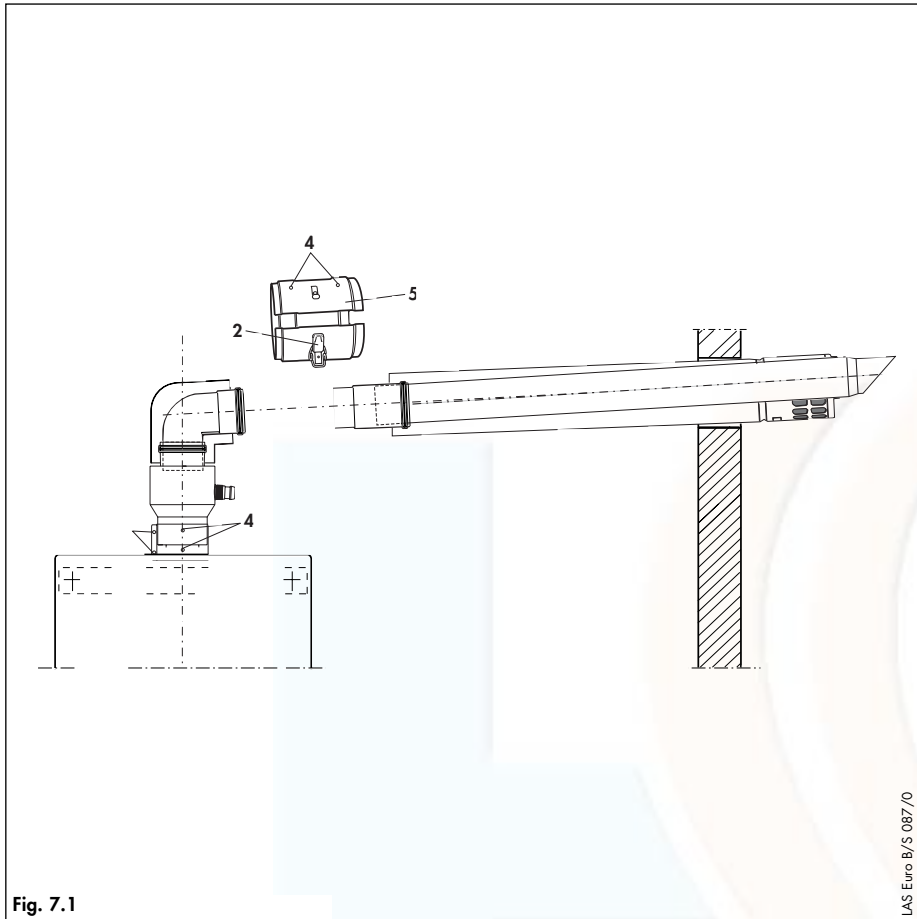

Fig. 7.1

LAS Euro B/S 087/0

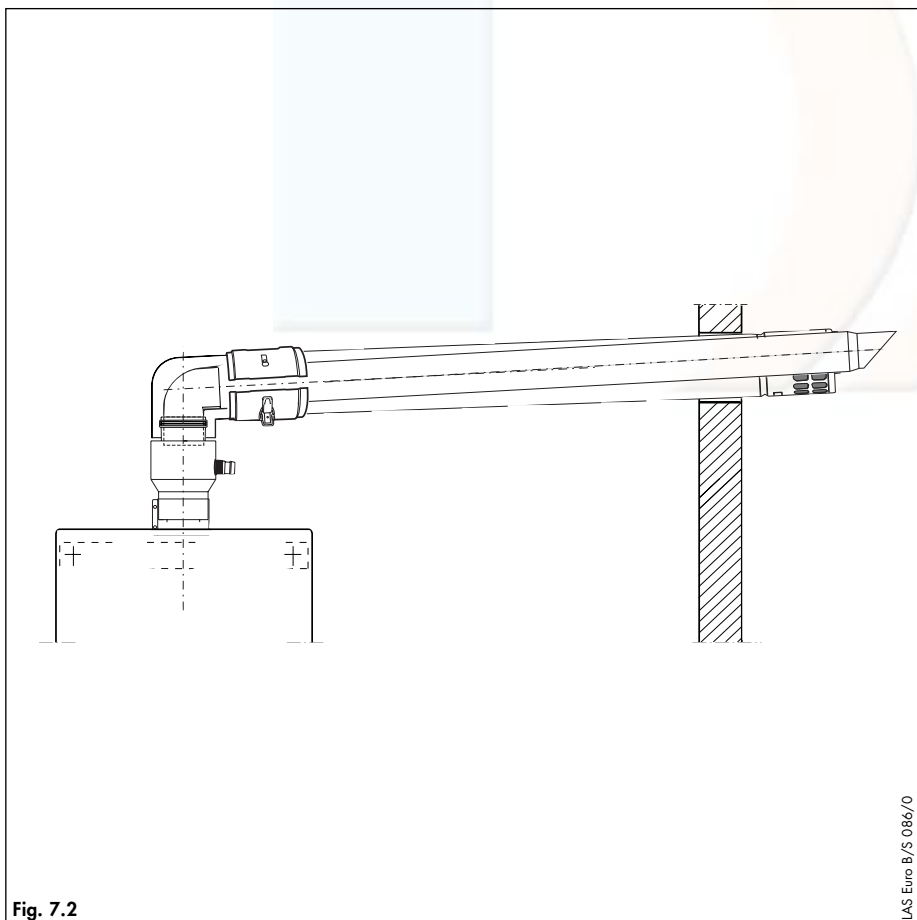

Fig. 7.2

LAS Euro B/S 086/0

How to fit sliding sleeves

NOTE:

For installations where there is insufficient movement to allow fitting of the flue into flue outlet, a sliding sleeve (Accy. No. 303 817) is available. When using the sliding sleeve both the air and flue ducts of the last extension must be shortened by a further 85 mm.

- Push the sliding sleeve over the cut end of the flue duct.
- Place the air duct clamp over the air duct.
- Pull back the sliding sleeve so that it engages into the socket of the boiler. Ensure that the sliding sleeve penetrates the socket such that there is at least 20 mm engagement at both ends of the sliding sleeve.
- Fit the air duct clamp over the air ducts of the extension/terminal and boiler outlet. Close the snap clamp.
- Drill two holes 3 mm diameter through the air duct clamp (the centre of the holes should be 6 mm from the edge of the clamp). Ensure that the drill does not penetrate the inner flue duct. Screw the air duct clamp to the air duct of the sleeve using the screw provided.
- Refer back to the Instructions for Installation and Servicing supplied with the boiler to complete the installation.







Head Office: vaillant Ltd.

Vaillant House ■ Medway City Estate ■ Trident Close

Rochester ■ Kent ME2 4EZ

Service Solutions 0870 6060 777 ■ Technical Advice 01634 292392